



SMARTER WAYS TO WORK™



B40 Straw Blower

Pine Straw Application is Now Fast & Easy.

The FINN B40 Straw Blower brings material application ease to small landscaping operations. You save time and energy by eliminating the tedious and time consuming process of hand application. And because the unit is both self-powered and portable, it's easy for you to apply pine straw in diverse locations.

With the B40 Straw Blower, you're ensured of faster and more uniform coverage than the traditional method of hand application. Blow pine straw evenly over large areas with ease. The B40 Straw Blower is capable of efficiently shredding and blowing up to 120 bales of Pine Straw an hour.*

Flexible & Effective Performance.

The B40 Straw Blower features a convenient discharge chute and with the optional 6" diameter, semi rigid hose, it is capable of applications up to 100 ft. away from the unit. It's the ideal solution for the proper application of pine straw. The B40 offers the flexibility to blow either standard straw or pine straw, making it a versatile machine for a variety of applications.

Specifically Designed To Meet Your Needs.

Like every piece of FINN equipment we produce, the B40 Straw Blower is the result of skilled and experienced manufacturing, as well as the valuable input received from our customers. We heard the call for a smarter way to apply pine straw and the FINN B40 Straw Blower does it with ease! You can cover large areas by using just the B40 without any optional equipment. For mulching beds or pinpointing your application, the 6" diameter semi rigid hose option is available in 50 ft. or 100 ft. lengths is all you need.

As the world leader for over 80 years in the design and manufacture of innovative, quality equipment for the erosion control industry, FINN Corporation is committed to your complete satisfaction.

Applications



Landscape



Golf Courses



Post Construction

Features & Benefits

- Shreds and blows up to 120 bales of pine straw an hour
- Convenient discharge chute and optional 6" diameter semi rigid hose in 50 ft. and 100 ft. lengths assures the most accurate directional discharge and operational ease
- Ideal solution for proper and precise application of pine straw
- Provides soil moisture retention and protection against wind damage
- Discharge head has a 360 degree rotation and 50 degree vertical travel
- Horizontal, collapsible feed tray which provides the most convenience and operator efficiency for feeding pine straw bales into the machine
- Unit available in both a skid configuration or trailer mounted configuration

* For optimal processing of Pine Straw the B40 should be operated at 1800-2200 RPM.

**B40
Straw Blower**

Technical Specifications

B40 Skid Mount

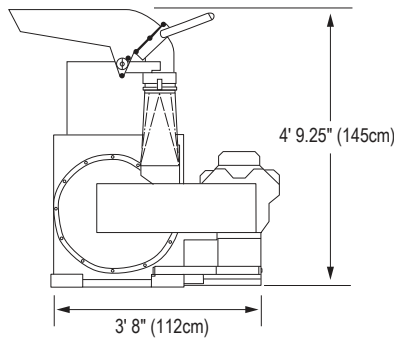
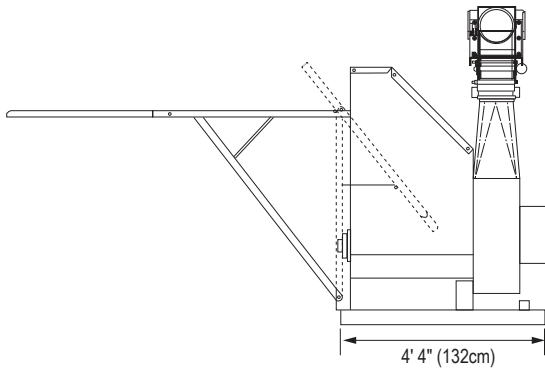

Power	Kohler CH640, 20.5 hp (15.3 kw), electric start
Engine Safety System	Low oil pressure shutoff
Capacity	Up to 120 bales per hour
Fuel Tank Capacity	4 gallon (15.1 liter)
Blower	17" (43 cm) diameter fan with 6 blades
Range	Up to 30 ft. (9.14 m)
Feed	Manual
Discharge Head	Dynamic, balanced, 360 degrees horizontal rotation and 50 degrees vertical travel
Trailer Option	Independent suspension rubber torsion axle, 20.5x8x10 highway tread tires, fenders, D.O.T highway lights, safety rails, parking jack, 2" (5 cm) ball hitch. Includes electric brakes with break away switch
Feed Tray	Horizontal, collapsible feed tray
Weight	B40S 565 lbs. (256 kg) B40T 1,165 lbs. (528 kg)
Hose Option	50 ft. (15.24 m) 6" diameter semi rigid hose 100 ft. (30.48 m) 6" diameter semi rigid hose

FINN Corporation has a policy of continuous product improvement, and reserves the right to change design and specifications without notice.

FINN Design® Logo are registered trademarks of FINN Corporation.



9281 LeSaint Drive | Fairfield, OH 45014-5457
Toll Free 800.543.7166 | 513.874.2818

Follow us on:    
www.FINNcorp.com