

**FINN****HydroSeeder®****Model T75**

The FINN T75 HydroSeeder is the ideal 700 gallon tank working capacity for landscapers and contractors who need high powered performance and productivity. The T75 fits in the FINN line as the feature-filled package right between the small tank sizes and larger trailer-mounted models. Weighing in as a trailer unit with a fully loaded weight of 10,000 GVW, the FINN T75T satisfies the ideal towing requirements of a ¾ ton or a 1 ton truck without a commercial license.

### **First-Rate Features & Design.**

The FINN T75 HydroSeeder shows-off the top performance, clean aesthetics and operator-friendly design you can expect from FINN. With the tower and hose reel standard equipment, this unit is the answer to achieving the most efficient one-man, one-step process to seeding, fertilizing, and mulching.

The T75 HydroSeeder features a hydraulically-driven and reversible mechanical agitator for fast and thorough mixing; liquid recirculation; agitator controls at each end of the tank for operator convenience; a large toolbox in the

hitch for storing hoses and nozzles; and a FINN-designed centrifugal pump that handles the thickest of slurries with ease and eliminates high maintenance belts and coupling. The rugged, reliable mechanics of the T75 provide long life and easy maintenance. And its low profile allows for easy material loading and excellent stability.

### **Multiple Applications. One Machine.**

The T75 HydroSeeder offers professional quality hydroseeding, fiber mulching, fertilizing, straw tacking, foliar feeding, dust control, remote watering, and a number of other efficient, cost-effective, and profitable applications. Use the T75 to tackle projects including residential and commercial areas, cemeteries, golf courses, sports fields, parks, office complexes, apartment complexes, condominiums, and more!

As the world leader for over 80 years in the design and manufacture of innovative, quality equipment for the green industry, and as the inventor of the HydroSeeder, FINN Corporation is committed to your complete satisfaction.

*Model shown may include optional equipment.*

# FINN HydroSeeder®

## Model T75

### T75T HYDROSEEDER® TRAILER

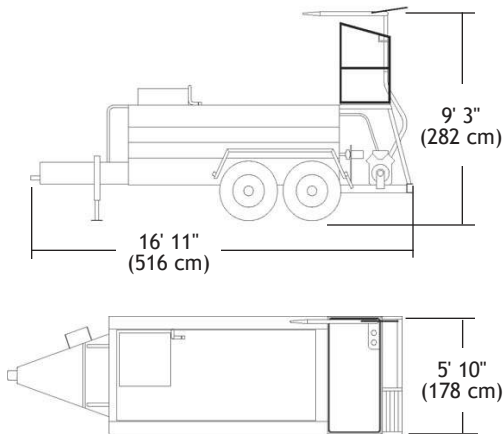

### T75S HYDROSEEDER® SKID MOUNT

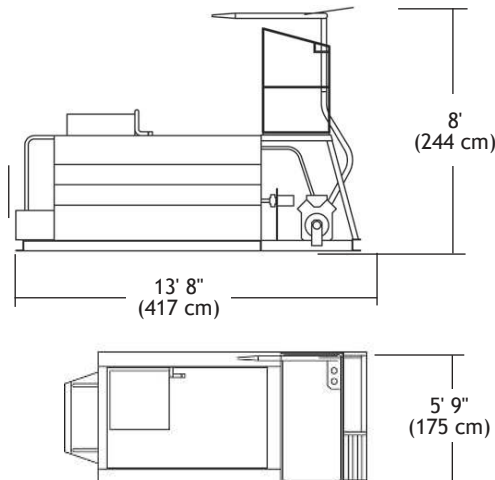

### FINN MODEL T75 TECHNICAL SPECIFICATIONS

POWER .....	Kohler CH730, 23.5 hp (17.5 kw), 2 cylinder, OHV, air cooled, gas	
ENGINE SAFETY SYSTEM .....	Low oil pressure shutoff	
TANK SIZE .....	820 gallon (3,100 liter) liquid capacity, 700 gallon (2,650 liter) working capacity	
LOADS PER ACRE* .....	4.29	
FUEL TANK CAPACITY .....	8.2 gallon (31 liter)	
PUMP .....	Centrifugal 3" x 1-1/2" (7.5 cm x 3.75 cm), 65 GPM @ 75 psi (245 lpm @ 5.3 kg/cm <sup>2</sup> ), 3/4" (1.9 cm) solid clearance, adjustable	
PUMP DRIVE .....	Direct drive through electric clutch, Pump drive is independent of agitator operation	
AGITATION .....	Mechanical paddle agitation and liquid recirculation	
AGITATOR DRIVE .....	Reversible, variable speed hydraulic motor drive (0-110 rpm), with control lever at front and rear of unit	
DISCHARGE DISTANCE .....	Up to 150 feet (45 m) from end of discharge tower	
MATERIAL CAPACITY .....	2,333 lbs. (1,058 kg) granular solids, 350 lbs. (159 kg) fiber mulch	
NOZZLES .....	(1) narrow fan, (1) wide fan, (2) long distance	
BRAKES .....	Electric with break-away switch	
LIGHTS .....	D.O.T., including identification lights and license plate bracket	
TIRES .....	ST225/75R15 load range D highway tread	
TRAILER AXLES .....	Tandem 5,000 lbs. (2,273 kg) rubber torsion with fenders	
HITCH .....	2 5/16" (5.87 cm) ball or heavy-duty lunette eye Includes large storage area in tongue	
HITCH WEIGHT .....	Approx. 1,400 lbs. (636 kg) maximum loaded	
EMPTY WEIGHT .....	T75T	3,250 lbs. (1,477 kg)
	T75S	2,450 lbs. (1,114 kg)
WORKING WEIGHT* .....	T75T	10,000 lbs. (4,541 kg)
	T75S	9,190 lbs. (4,177 kg)

\*Loads per acre based on an application rate of 1500 lbs. mulch/acre.

\*Working weights are approximate and do not include stored materials.

FINN Corporation has a policy of continuous product improvement, and reserves the right to change design and specifications without notice.

HydroSeeder® and the FINN Design® Logo are registered trademarks of FINN Corporation.



9281 LeSaint Drive • Fairfield, OH 45014-5457  
Toll Free 800.543.7166 / 513.874.2818  
FINNcorp.com