

FINN

HydroSeeder®

Model T170



The FINN T170 HydroSeeder boasts a top-notch 1,500 gallon tank working capacity engineered to tackle a wide array of mid to larger-sized hydroseeding projects. From large residential and commercial properties, highway roadsides, industrial parks, sports fields, mine reclamation sites and more, the T170 is an economical choice for optimum power, performance and production.

FINN developed HydroSeeder technology in 1953, and we've been the industry leader in quality and innovation ever since. With the FINN T170, you have proven and reliable FINN quality for all your hydroseeding applications.

High Production. Big Value.

The FINN T170 HydroSeeder features an unequalled engine and pump package resulting in utmost pump pressure, slurry flow and high performance capabilities. The T170 is equipped with the time-tested and field proven "clump" technology. The "clump" (clutch/pump) technology uses a unique single shaft design to maximize mechanical efficiency, making it the most efficient pump available.

Extreme Efficiency.

The T170 is all about operator convenience. The discharge boom is located in a centralized location to increase operator comfort and rear sweeping pattern; an engine control panel is integrated into the discharge boom tower featuring a new electronic display panel, as well as engine start/stop, throttle switch, and safety horn; a loading hatch with a larger opening, rotated lid and stainless steel bag cutter enables a simpler, more efficient loading process; and enhanced operator platform and access ladder are perfect for greater comfort and accessibility. Also standard on the T170 HydroSeeders are the conveniently located fill port for sump filling and the heavy-duty suction line gate valve.

As the world leader for over 80 years in the design and manufacture of innovative, quality equipment for the green industry, and as the inventor of the HydroSeeder, FINN Corporation is committed to your complete satisfaction.

Model shown may include optional equipment.

T170 HYDROSEEDER®

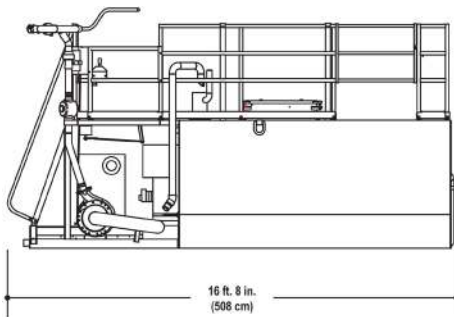
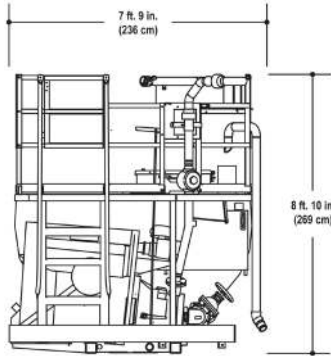

FINN MODEL T170 TECHNICAL SPECIFICATIONS

POWER	Cummins QSF 2.8 Diesel Tier 4F, 65hp (48 kW), with over-center clutch. Vibration isolated. Controls include: clutch, agitator direction and speed, discharge boom and recirculation control valves, engine throttle, safety horn, and engine start/stop
ENGINE SAFETY..... SYSTEM	Low oil pressure, electronic engine control and monitoring
TANK SIZE	1,750 gallon (6,625 liter) liquid capacity, 1,500 gallon (5,678 liter) working capacity
LOADS PER ACRE ¹	2
FUEL TANK	38 gallon (145 liter) CAPACITY
PUMP	Centrifugal 4" x 2" (10.2 cm x 5 cm), 320 GPM @ 115 psi (1,210 lpm @ 792 kPa), 1" (2.54 cm) solid clearance
PUMP DRIVE.....	In-line single clutch/pump shaft design with over-center clutch. Pump drive is independent of agitator drive.
AGITATION	Mechanical paddle agitation and liquid recirculation.
AGITATOR DRIVE.....	Reversible, variable speed hydraulic motor drive (0-130 rpm)
DISCHARGE..... DISTANCE	Up to 200 ft. (61 m) from discharge tower
MATERIAL..... CAPACITY	5,000 lbs. (2,268 kg) granular solids, 750 lbs. (340 kg) fiber mulch
NOZZLES	(2) narrow fan, (2) wide fan, (2) long distance
EMPTY WEIGHT ²	6,770 lbs. (3,071 kg)
WORKING WEIGHT ²	24,300 lbs. (11,022 kg)

¹Loads per acre based on an application rate of 1500 lbs. mulch/acre.

²Working weights are approximate and do not include options or stored materials. Working weights assume maximum tank liquid capacity and maximum granular solids material capacity.

FINN Corporation has a policy of continuous product improvement, and reserves the right to change design and specifications without notice.

HydroSeeder® and the FINN Design® Logo are registered trademarks of FINN Corporation.