

FINN **CORPORATION**

9281 LeSaint Drive • Fairfield, Ohio 45014
Phone (513) 874-2818 • Fax (513) 874-2914

Sales:1-800-543-7166



B-40 Mulch Spreader **Parts and Operator's Manual**

Model **S0** Serial No. _____

INDEX

Safety First	1
Safety Summary Section	2-4
Definition of Mulching	5
Towing Vehicle	5
Loading Bales	5
Pre-Start Check	6
Equipment Check	6
Starting Procedure	6-7
Crew Members and Their Duties	7
Blower Discharge	7
Cleaning and Maintenance	8
4-8 Hours	8
Daily Clean-up Maintenance	8
Weekly Maintenance	8
Every 100 Hour Maintenance	8
Lubrication and Fluids Chart	9
Notes	10
Parts Manual Section	11-23
Blower Shaft Assembly	13
Discharge Head Assembly	14-15
Beater Box and Feed Chute	16-17
Control Box Wiring	18
Trailer Wiring	19
Trailer Assembly	20
Axle & Hub Assembly	21
Brake Assembly	22
Decals	23
Warranty	24
Warranty Registration Card	25

SAFETY FIRST

With any piece of equipment, new or used, the most important part of its operation is **SAFETY!**

Finn Corporation encourages you and your employees to familiarize yourselves with your new equipment and to stress safe operation.

The first four pages of this manual are a summary of all the main safety aspects associated with this unit. Be sure to read completely before operation of machine.



This symbol is used throughout the operation and maintenance sections of this manual to call attention to safety procedures.

- Pay Attention -



DANGER: Immediate hazards which **WILL** result in severe personal injury or death.



WARNING: Hazards or unsafe practices which **COULD** result in severe personal injury or death.



CAUTION: Hazards or unsafe practices which **COULD** result in minor personal injury or product or property damage.

IMPORTANT: Indicates that equipment or property damage could result if instructions are not followed.

NOTE: Gives helpful information.

Finn Corporation

CALIFORNIA

Proposition 65 Warning

The engine exhaust and some of its constituents are known to the State of California to cause cancer, birth defects, and other reproductive harm.

CALIFORNIA

Proposition 65 Warning

Battery posts, terminals and related accessories contain lead and lead compounds, chemicals known to the State of California to cause cancer and reproductive harm. Wash hands after handling.

MULCH SPREADER SAFETY SUMMARY SECTION

It is important that all operators of this machine are familiar with all of the safety aspects mentioned below and have read the entire Operator's Manual before operating the machine. Always keep a copy of this manual with the machine. It is the responsibility of the operator of the machine to fully understand this safety sheet. Remember that YOU are the key to safety. Good safety practices protect not only you but also the people working with and around you. Keep in mind that this safety sheet is written for this type of machine only. Practice all other usual and customary safe working precautions; and above all, remember that safety is up to you.

The FINN MULCH SPREADER is intended to be used as an applicator of vegetative hay or straw mulches onto the seedbed. Its use with other products or for other applications must be by approval of the product's manufacturer. If there are any questions contact FINN Corporation at 1-800-543-7166.

I. PRE-START EQUIPMENT CHECK (equipment check is to be made with the engine off):

1. Check hitch and hitch bolts, safety chains, lights, brakes and breakaway switch. Verify that the hitch ball is the correct size for the coupler.

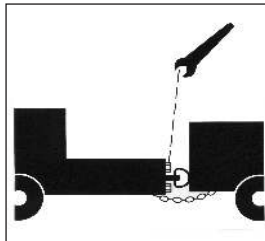

2. Check that all guard railing is in place and secure.
3. Verify that all guards are in place.
4. By carefully looking in the shredder box, inspect the shredder box for foreign objects.
5. With the ignition switch on, verify that the signal horn is operating correctly.
6. Make sure no one is working on or inside the machine. Signal "All Clear" before starting the engine.

II. MACHINE OPERATION:

1. Always wear safety goggles when operating or feeding the machine. Other safety attire such as safety shoes, ear protection, gloves, hard hats, dust masks, etc., should be worn as required by warning decals on machine, operator's manuals, or job-site requirements. Remove rings, watches, etc. Avoid loose fitting clothing that may get caught in rotating machinery.

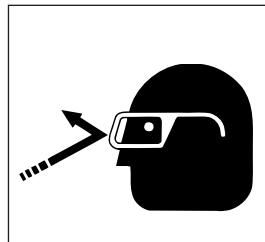

2. Do not operate the machine without all guards in place.

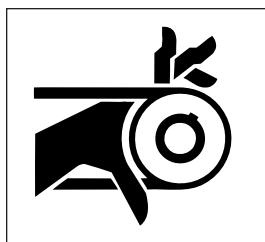

3. Make sure the discharge spray area is clear of all persons, animals, etc.
4. The driver of the carrying or towing vehicle is responsible for the safety of the operator(s) and feeder(s) of the machine. Make sure the driver is aware of and avoids all possible hazards to the operator(s) on the machine, such as tree limbs, low power lines, etc. Vehicles on which equipment is mounted or towed must be started or stopped gradually. Avoid abrupt starts and stops. Never operate on a slope or a hill that may endanger the operator(s). All personnel should review and be familiar with start/stop signals between the driver and operator(s) before operation of the equipment.

5. Operator(s) of equipment should never ride on machine at speeds greater than 5 M.P.H. (8km/h).

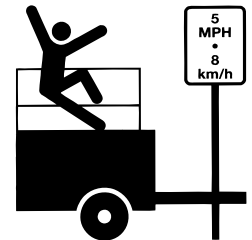

6. Never operate machine in an enclosed area without venting the exhaust of both the equipment and the vehicle on which the equipment is mounted or towed. Deadly carbon monoxide fumes can accumulate.

7. Never operate this or any other machinery when fatigued, tired, under the influence of alcohol, illegal drugs or medication. You must be in good physical condition and mentally alert to operate this machine.



8. Never modify the machine. Never remove any part of the machine (except for service and then reinstall before operating).
9. Use proper means for mounting and dismounting of machine. Never mount or dismount a moving machine.
10. Do not aim discharge at people, animals, etc. Only aim the discharge at the intended seedbed.

11. Do not open any doors or access panels while machine is in operation. Severe injury may result from rotating parts.



12. Do not attempt to pull anything out of the feed chute or shredder box when machine is in operation. Shut down the engine, using OSHA lockout/tagout procedure (29CFR 1910.147) before removing any foreign objects. Signal "All Clear" before restarting the machine.

III. MAINTENANCE:

1. Before servicing the machine, turn off engine and allow all moving parts to stop. Disconnect the battery cables to prevent accidental starting of the machine. Tag the engine operating area to show that the machine is being serviced. Use lockout/tagout procedure (29 CFR 1910.147).

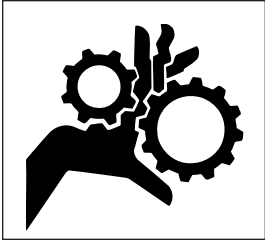

2. On trailer units perform general maintenance such as checking the safety chains, hitch and hitch bolts, tires, and brakes. Repair or replace if worn or broken. Never operate machine on improperly inflated or damaged tires. Always use a safety cage or cable restraints when reinflating a repaired tire.

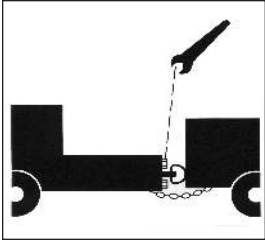

3. Battery maintenance. Lead-acid batteries contain sulfuric acid which damage eyes or skin on contact. Always wear a face shield to avoid acid in the eyes. If acid contacts eyes, flush immediately with clean water and get medical attention. Wear rubber gloves and protective clothing to keep acid off skin. Lead-acid batteries produce flammable and explosive gases. Keep arcs, sparks, flames, and lighted tobacco away.
4. Filling of fuel. Never fill the fuel tank with the engine running, while smoking or when near an open flame. Never smoke while handling fuel or working on the fuel system. The fumes in an empty container are explosive. Never cut or weld on fuel lines, tanks, or containers. Move at least 10 feet (3 meters) away from fueling point before starting engine. Wipe off any spilled fuel and let dry before starting engine.

NOTE: Be careful not to allow fuel, lubricant, hydraulic fluid, or cooling fluids to penetrate into the ground or be discharged into the water system. Collect all used fluids and dispose of them properly.

5. It is recommended that only authorized genuine FINN replacement parts be used on the machine.
6. Make certain that all decals on the machine are maintained in good legible condition. Replacement decals are available through FINN Corporation by specifying the part number shown in the lower right hand corner of the decal. See page 4 for the current set of safety decals mounted on the unit. See Parts Manual for the location and quantity of all decals on this unit.

CURRENT SET OF SAFETY DECALS

CAUTION

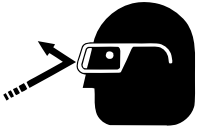

Wear eye protection around operating equipment.

23519

WARNING



**THROWN OBJECT HAZARD
KEEP AWAY**

- To prevent serious injury or death from thrown objects:
- Stay away from discharge area during operation. Keep others away.
- Do not point discharge toward people, animals or property

SW805

WARNING

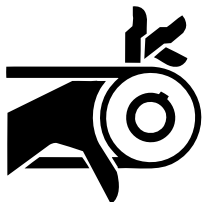

Do not operate without guards in place.

12179

CAUTION

AREA AROUND ENGINE MUST BE KEPT CLEAR OF FLAMMABLE MATERIAL

P/N 35101

WARNING

BREAKAWAY SWITCH
Do not use for parking. Attach cable to towing vehicle with slack for turning. Engine battery on trailer must be charged and hooked up for proper breakaway function.

P/N-23423

DANGER

HOT EXHAUST

012278



SAFETY CHAIN INSTALLATION

CAUTION

Both the single and double chains must be crossed under the tongue. They must be oriented in such a manner as to prevent the tongue from dropping to the ground in the event of failure to the hitch, coupler or ball. The Chains must be connected to the towing vehicle so that the slack for each length of chain, between the trailer and the towing vehicle, is the same and must have no more slack when in use than is necessary to permit proper turning of the vehicles. The forward end of the chain must be attached to the towing vehicle, not to the ball, but to the hitch or other frame member. The chain must be looped around the member and hooked back into itself.

P/N-31228

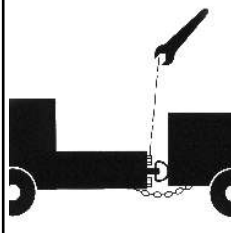

CAUTION

Always inspect tow vehicle and equipment hitch before towing. Tighten all hitch bolts and properly connect wiring and safety chains.

P/N-31227

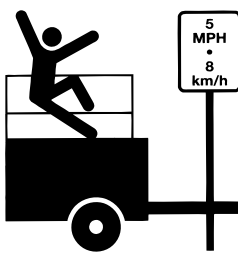

CAUTION

Personnel should not ride this equipment at speeds greater than 5 MPH (8 km/h).

20970



DANGER

Rotating Parts.
Turn off engine and allow all parts to stop completely before opening door, removing guards or attempting service.

2006B

Operation and Maintenance

Manual for

B-40 Mulch Spreader

INTRODUCTION:

This manual is designed for step by step instructions of the operation, care, and maintenance of the B-40 Mulch Spreader and, in addition, it contains illustration and descriptions of a complete list of parts and components for easy identification. For best results and to insure longer life of the equipment, please follow the instructions carefully. For your safety read the entire manual before operation of this unit.

DEFINITION OF MULCHING:

Mulching is the process whereby a vegetative mulch such as hay or straw, sometimes excelsior or other wood product or other vegetative material is spread on previously seeded areas to promote germination, while providing temporary erosion control.

THE FINN B-40 MULCH SPREADER AND HOW IT WORKS:

The Finn B-40 Mulch Spreader will apply vegetative mulch at a fast and uniform rate utilizing a minimum amount of manpower.

The baled vegetative mulch material is placed on the feed chute and separated by the bale feeder as he feeds these bales into the beater box. In the beater box a combination of beater chains and air currents separates the mulch into individual fibers, which are drawn into the blower housing and blown through the discharge assembly onto the seedbed.

TOWING VEHICLE:

The truck used to tow the Finn B-70 Mulch Spreader should have a bed large enough to carry the quantity of mulch needed for economical operation. The truck must be equipped with a 2" ball rated 3000 lbs. (1358kg). The tow vehicle must be able to support 400 lbs. (181kg) down on its hitch.

LOADING BALES:

Load the bales of mulch on the truck bed with binder twine or wire on top rather than on the side. This makes it easier to grab the bales while the Mulch Spreader is in operation.

Place the first layer of bales "lengthwise" on the truck. The second layer of bales should be placed "crosswise". Alternate successive layers lengthwise and crosswise in order to secure the load.

Leave enough room at the rear of the truck bed for the bale handler to stand.

PRE-START CHECK:

SAFETY CHECK TO INSURE OPERATOR SAFETY:

1. A. Skid Unit - Check condition of all mounting hardware securing the Mulch Spreader to the truck bed.
B. Trailer Unit - Inspect hitch, safety chains, lights, brakes and breakaway switch.
2. Insure that all guards are in place.

EQUIPMENT CHECK:



CAUTION: Equipment check is made with the engine off and all rotating parts stopped.

1. Tool kit - see that it contains following items: twine knife (#20057) and engine operator's manual.
2. Check beater box for foreign objects that could damage the equipment or injure workers.
3. Check fuel tank. Use Gasoline only.
4. Check engine oil - refer to engine operator's manual.
5. Inspect air cleaner for dust and dirt - refer to engine operator's manual.
6. Check beater chains and their mounting pins for damage or wear. Replace if necessary.
9. Lubricate equipment - use hand gun only (see lube chart page 9).

STARTING PROCEDURE:



CAUTION: See safety section of the manual (pages 1-4) before operating the machine.

1. Place the clutch switch in the "DISENGAGE" position.
2. Set throttle about ¼ open.
3. Pull Choke control out.
3. Turn key counter clockwise until starter engages, and the engine starts.
4. Push the choke control in for even running.
5. Allow the engine to warm up for 3 to 5 minutes.

NOTE: This engine has a safety system that will shut the engine off if the engine oil pressure decreases below an acceptable level.

6. With the engine running between 1250-1750 rpm (check tachometer), move the clutch switch to the "ENGAGE" position. The clutch is then activated using an electrical pulse and will gradually engage over a 3 second time span.

NOTE: When starting your B-40 Mulch Spreader under cold conditions: until engine warms to the appropriate operating temperature it may be necessary to slightly increase the choke before engaging the blower.

CREW MEMBERS AND THEIR DUTIES:

1. The Operator controls the placement of the mulch on the seedbed by moving the discharge assembly. He also controls the movement of the towing truck along the seedbed by using a predetermined set of hand signals.
2. The Bale Handler operates from the truck bed and supplies the feeder with bales of mulch material, cut side up.
3. The Bale Feeder cuts and disposes of the twine or wire; separates the bale in 1½” to 2” bats and feeds those into the shredder box allowing about a 10” space between bats. Uniform feeding assures fast separation and more uniform application.
4. The Truck Driver follows the directions of the operator for the movement of the towing truck. The truck driver should be cautious in starting or stopping the truck so that the crew members are not thrown off balance.

BLOWER DISCHARGE:

The B-40 Mulch Spreader should be towed to a point approximately 20 ft (6 m) from the area where the mulch is to be applied. The operator elevates the discharge spout about 10° above the plain of the seedbed so that the mulch floats onto the seedbed.

Do not drive the mulch into the seedbed with air pressure. The higher the tube is held, the more uniform the application will be.

A full circle horizontal travel of the discharge spout allows the operator to vary the direction of the discharge spout according to the prevailing winds. The tube should never be directed into the wind, towards any persons, or at the towing vehicle. Use the engine throttle to control the distance of the mulch.



CAUTION: Be sure beater chains are mounted opposite each other at all times to avoid throwing the blower shaft out of balance.

If any obstruction stops the flow of mulch, immediately disengage clutch and shut off engine. Do not reach into the beater box or attempt any adjustment until the engine and all rotating parts have stopped. When the obstruction has been removed, the motor can be restarted and mulch application can continue.



DANGER: Do not reach into the beater box or attempt any adjustment until the engine and all rotating parts have stopped.

CLEANING AND MAINTENANCE:

AFTER FIRST 4 - 8 HOURS OPERATION:

1. Check and adjust belt. Proper tension is obtained when 3/8" (1cm) of belt deflection is obtained at the center of the belt span with a force of 5 (used belt) to 7 (new belt) pounds (2.2 to 3.2 kg).
2. Retorque wheel lugs (85-98 ft.lbs. (12-13 kg-m))- again after 7 days. (Trailer option only).
3. Change engine oil and filter.

DAILY CLEAN-UP MAINTENANCE:

Follow this procedure daily to keep the equipment in good operating condition:

1. Clean the air cleaner following the instructions in the engine operator's manual.
2. Clean the beater chains, making sure to remove all twine, wire, and other foreign objects. Check pins and nuts.
3. Lock the discharge tube into place.
4. Check engine oil level.
5. Check hitch bolts and safety chains.

WEEKLY MAINTENANCE:

After each 50 hours of operation, follow this procedure:

1. Lubricate bearings with general-purpose chassis lubricant, using a grease gun. Wipe each bearing before lubrication to remove dirt and prevent overheating.
2. Inflate tires to 35 psi (241 kPa).
3. Check belt adjustment.

EVERY 100 HOUR MAINTENANCE:

1. Change engine oil, following engine manufacturer's recommendations after every 100 hours.
2. Change the engine oil filter cartridge with every oil change (once every 100 hours)



CAUTION: Adjust only while engine is off.

LUBRICATION AND FLUIDS CHART

Ref. No.	Location	Lubricant	Frequency	Number
1.	Grease drive shaft bearings	CL	Weekly	2
2.	Check fuel tank level	GA	Daily	1
3.	Check engine oil level	MO	Daily	1
4.	Check air cleaner		Daily	1
	Service pre-cleaner element		Every 25 Hours	1
	Change air cleaner element		Every 100 Hours	1
5.	Change engine oil & filter	MO	Every 100 Hours	1

LUBRICANT OF FLUID USED

CL Chassis Lubricant
 MO Motor oil SAE 30 CD/SF
 GA Gasoline Fuel

TIME KEY

DAILY △

WEEKLY □

EVERY 100 HOURS ▱

FLUID CAPACITIES

Fuel - 5.5 gallons
 Engine Oil - 2.1 Quarts

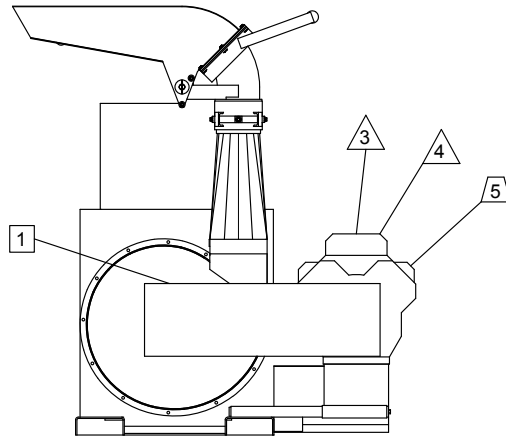
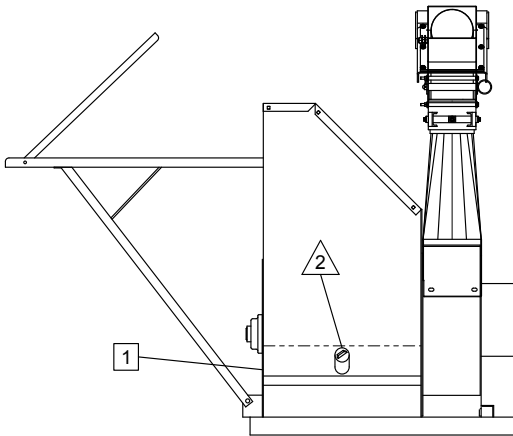

NOTES

B-40 Mulch Spreader

Parts Manual

Model SO

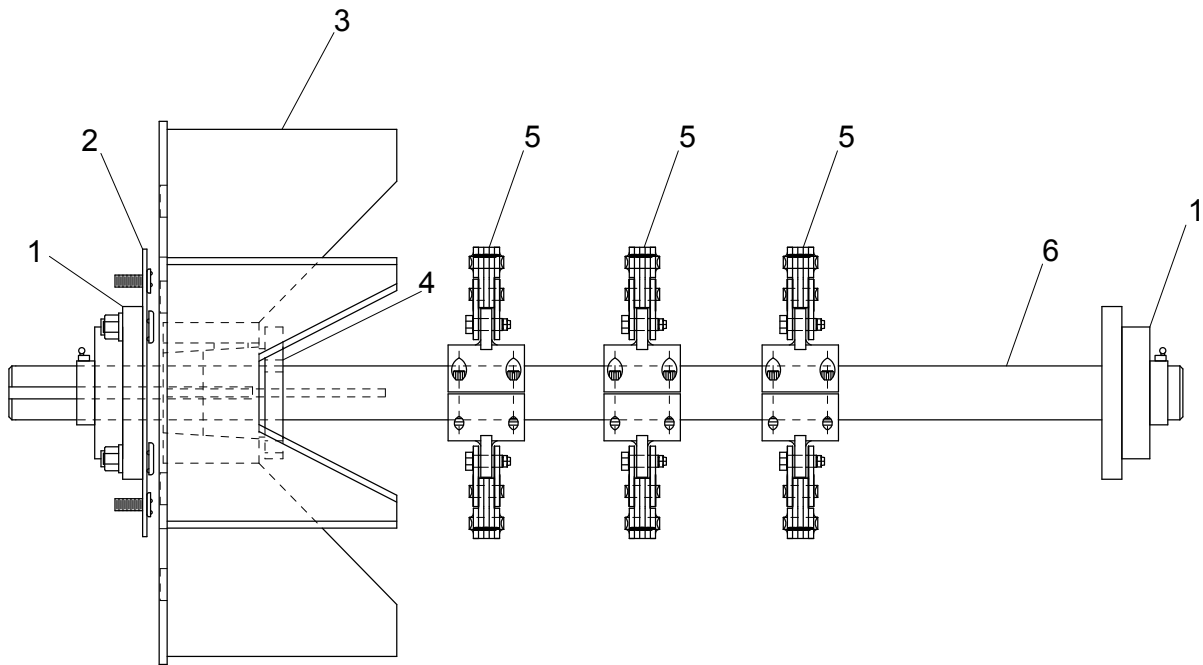

BLOWER SHAFT ASSEMBLY

Ref. No.	Part No.	Description	No. Req'd.
1	035033	Blower Shaft Bearing	2
2	035021	Shaft Pad	1
3	035104	Blower Blade Weldment	1
4	035099	Blower Bushing w/Key	1
	190125-70	Blower Blade Key	1
5	035081	Beater Chain Assembly	3
	022487	5/16 Flex Lock Pivot Nut	6
	020119	Hardened Shoulder Bolt	6
	035080	Breaker Hub Weldment	3
	020238	2 Pitch Beater Chain	6
6	035013	Blower Shaft	1
	035074	Driven Sheave	1
	035075	Gripnotch Belts - Matched set of 2	1

WHEN ORDERING PARTS, BE SURE TO STATE SERIAL NUMBER OF MACHINE

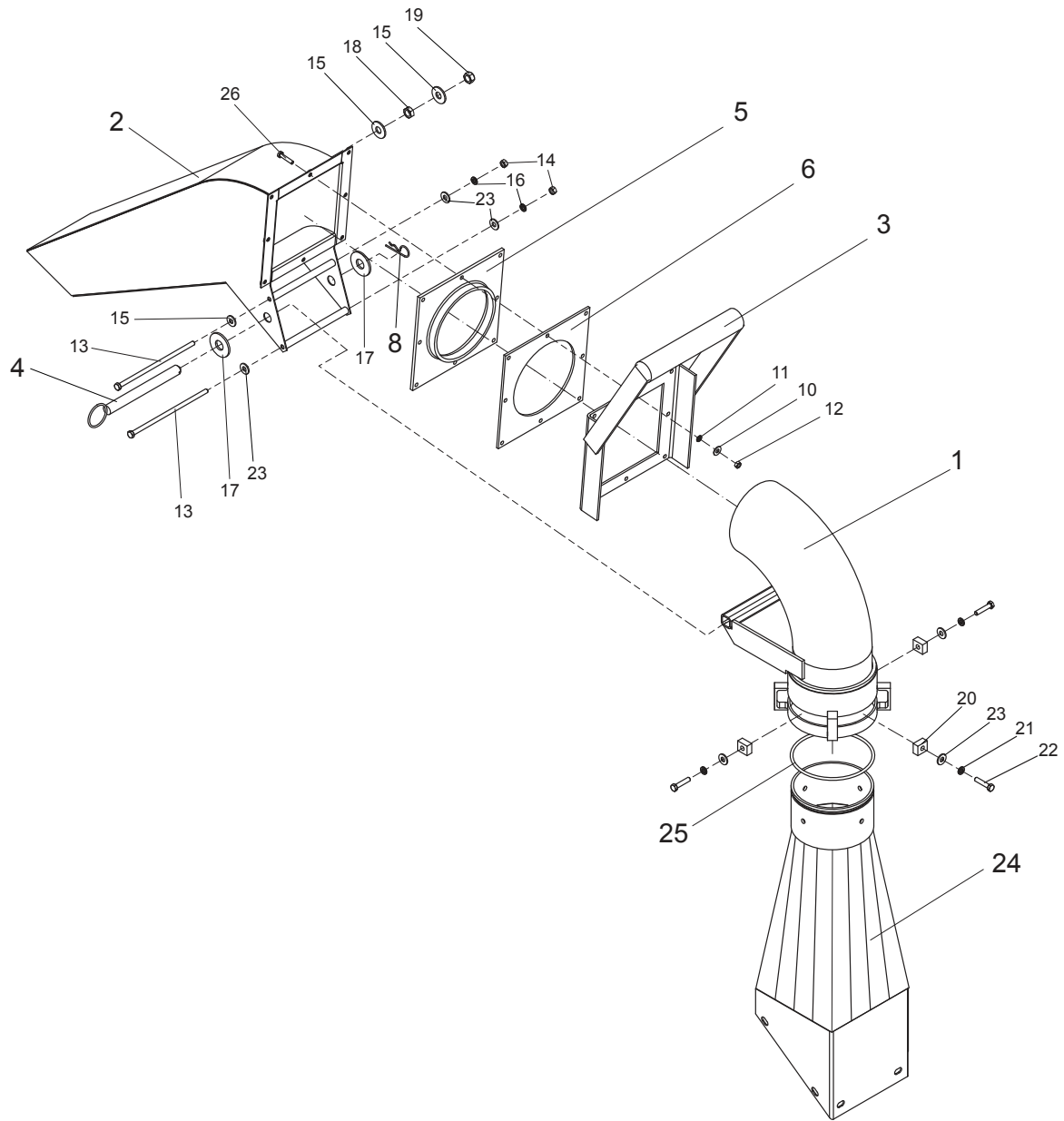

WHEN ORDERING PARTS, BE SURE TO STATE SERIAL NUMBER OF MACHINE

DISCHARGE HEAD ASSEMBLY

Ref. No.	Part No.	Description	No. Req'd
1	035115	Discharge Elbow	1
2	035111	Discharge Head	1
3	035117	Discharge Head Handle	1
4	035118	Pivot Pin	1
5	035114-01	Discharge Seal - Rubber	1
6	035114-02	Discharge Backing Seal - Rubber	1
7	035116-03	Head Stop Tube	2
8	022962	Hair Pin - Cotter	1
9	X0420	1/4" Bolt	8
10	W04F	1/4" Flat Washer	16
11	W04L	1/4" Lock Washer	8
12	Y04	1/4" Hex Nut	8
13	X05128	5/16" Bolt	2
14	Y05	5/16" Hex Nut	2
15	W08F	1/2" Flat Washer	2
16	W05L	5/16" Lock Washer	2
17	W12F	3/4" Flat Washer	2
18	Y08J	1/2" Jam Nut	1
19	Y08L	1/2" Lock Nut	1
20	035024-09	Swivel Spacer	4
21	W05L	5/16" Lock Washer	4
22	X0524	5/16" Bolt	4
23	W05F	5/16" Flat Washer	8
24	035042	Transition Weldment	1
25	035037	Discharge O-Ring	1

**WHEN ORDERING PARTS, BE SURE TO STATE
SERIAL NUMBER OF MACHINE**

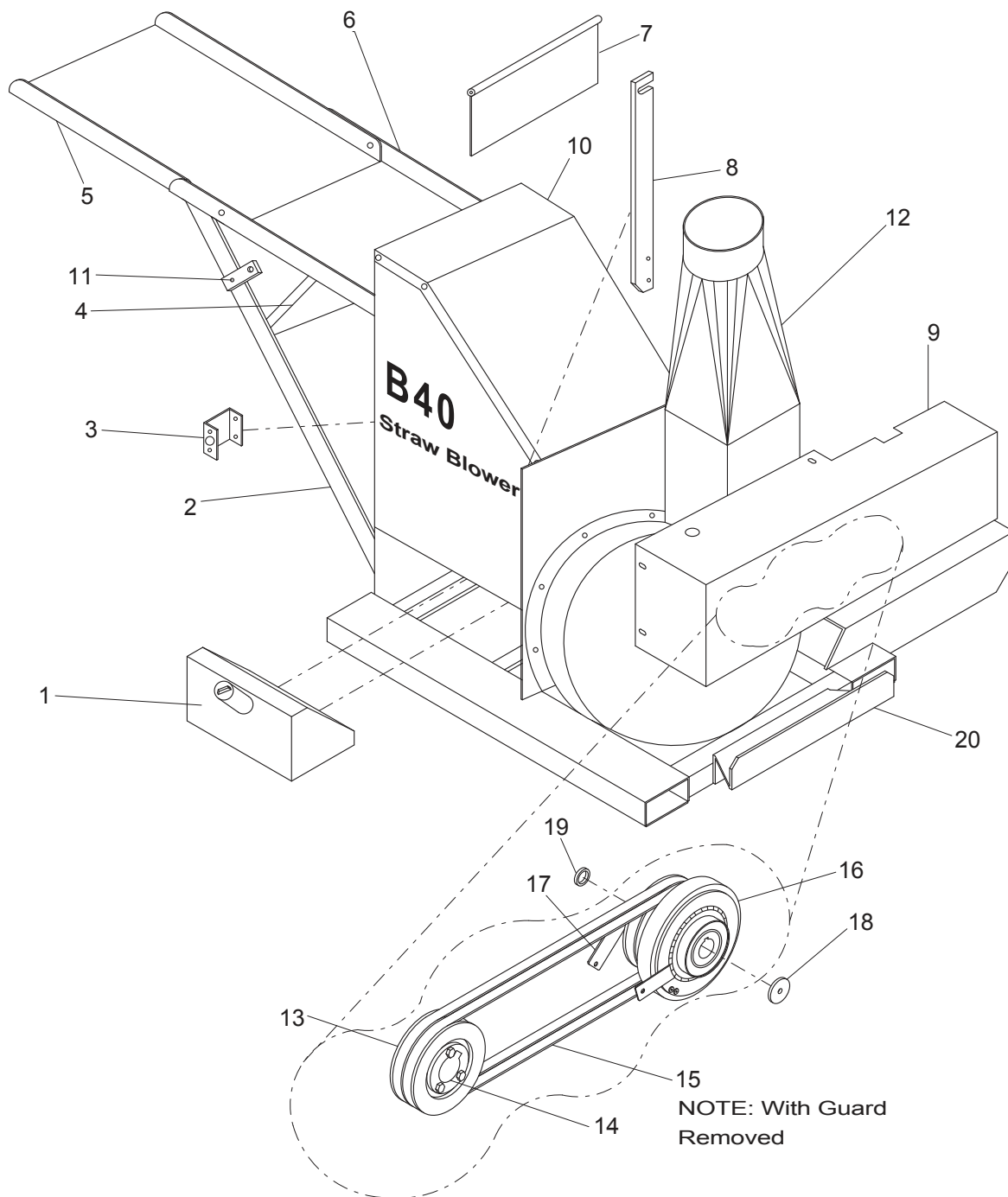

WHEN ORDERING PARTS, BE SURE TO STATE SERIAL NUMBER OF MACHINE

BEATER BOX AND FEED CHUTE

Ref. No.	Part No.	Description	No. Req'd
1	035022	Gasoline Fuel Tank	1
	035012-02	Fuel Tank Holder	1
	007914	Gas Cap	1
2	035004-01	Feed Chute Support	1
3	035109-02	Shaft Guard Cover	1
	035109-01	Shaft Cover Guard Base	1
4	035004-02	Chute Gusset	1
5	035113-01	Feed Chute Extension	1
6	035113-02	Feed Chute	1
7	035018	Feed Swing Door	1
	035018-04	Swing Rod	1
8	035012-01	Tube Hold Down	1
	031245	Snapper Pin	1
9	035070	Belt Guard	1
	035071	Belt Guard Support	1
10	034008	Beater Box Cover	1
11	035018-08	Feed Chute Latch	1
	035041	Cotterless Hitch Pin	1
12	035042	Transition Weldment	1
13	035074	Clutch Sheave	1
14	030876	Clutch Sheave Bushing	1
15	035075	Gripnotch Belts - Matched set of 2	1
16	035073	Electric Clutch	1
17	035069-03	Clutch Retaining Strap	1
	X0464	Retainer Bolt	1
	Y04L	Retainer Nut	1
	035025	20 HP Engine	1
18	035069-05	Clutch Retaining Washer	1
19	035069-04	Notch Spacer	1
20	035083	Bumper Guard	1

**WHEN ORDERING PARTS, BE SURE TO STATE
SERIAL NUMBER OF MACHINE**

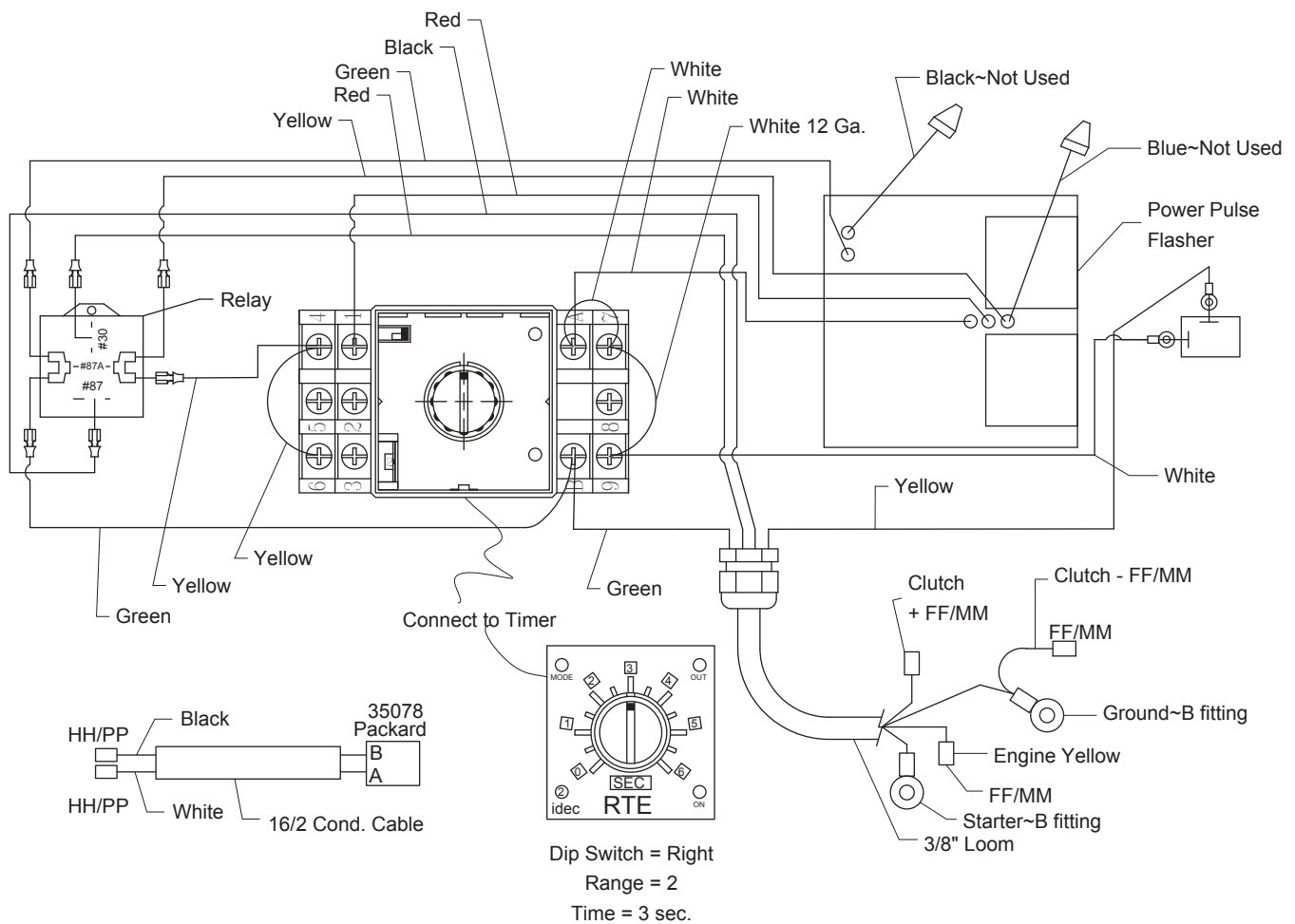

CONTROL BOX WIRING

Part No.	Description	No. Req'd
035102	Control Box Wiring	1
035098	Power Pulse Flasher	1
052112	Toggle Switch	1
080526	Toggle Switch Boot	1
055122	Idec Timer	1
055125	Idec Timer Base	1
FW71749-02	Relay	1
010516	Ground Strap	1
080524	Battery	1
035073	Electric Clutch	1
035103	Enclosure Box	1
031031	2 GA. Red Battery Cable	1

WHEN ORDERING PARTS, BE SURE TO STATE SERIAL NUMBER OF MACHINE

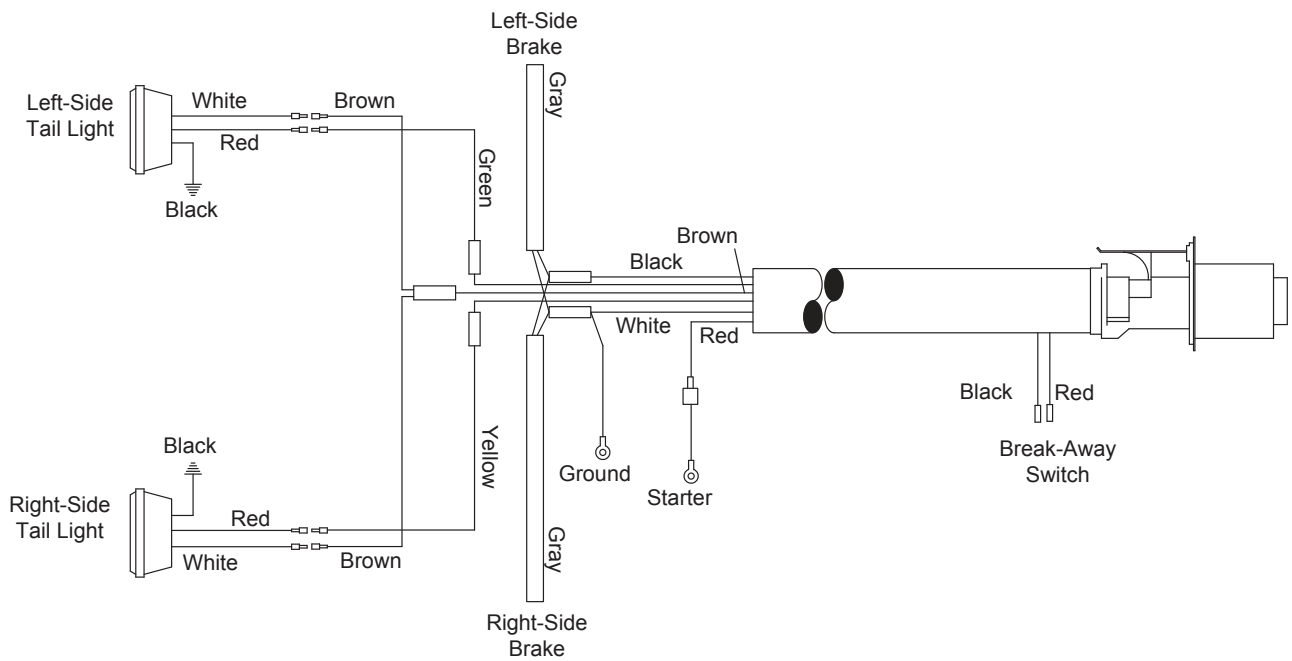

TRAILER WIRING

Part No.	Description	No. Req'd
035060	Trailer Wiring	1
060069	Plug & Receptacle	1
005137	Left-Hand Taillight	1
005138	Right-Hand Taillight	1

WHEN ORDERING PARTS, BE SURE TO STATE SERIAL NUMBER OF MACHINE

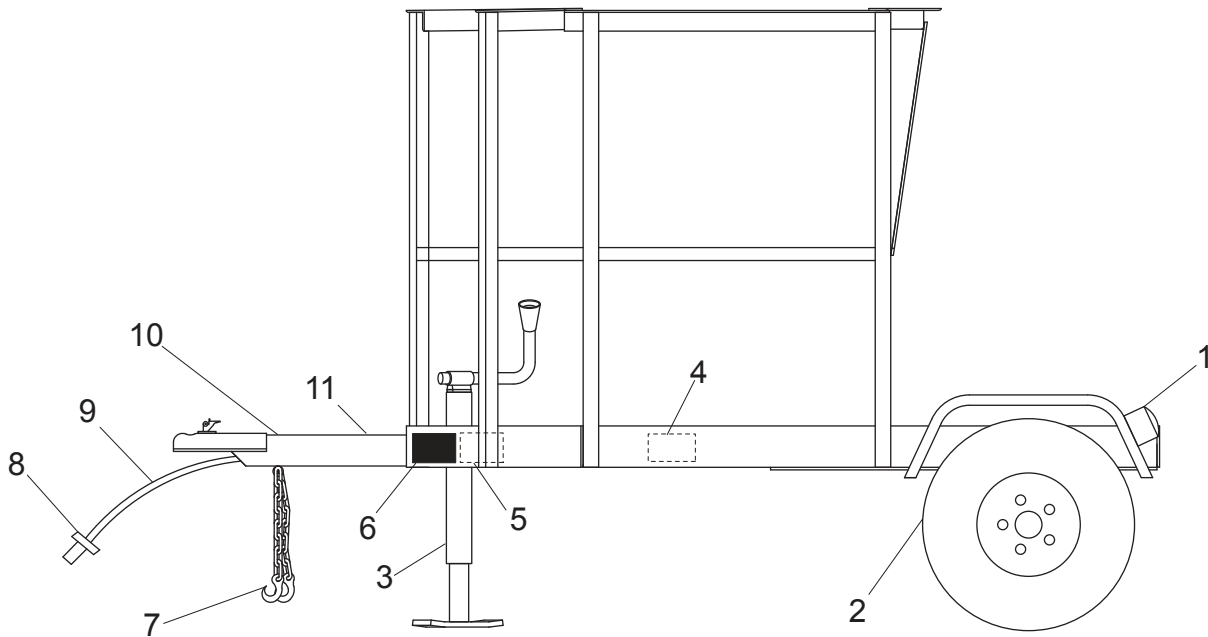

TRAILER ASSEMBLY

Ref. No.	Part No.	Description	No. Req'd
1 LH	005137	Left-Hand Taillight	1
1 RH	005138	Right-Hand Taillight	1
2	055503	Rubber Torsion Axle	1
	055493	Rim & Tire Assembly	2
3	031189	Jack	1
4	020970	Decal "Cation Do Not ..."	1
5	031228	Decal "Saftey Cahin ..."	1
6	031227	Decal "Always Inspect..."	1
7	031180	Grab Hook	2
	190028	Saftey Chain	6'
8	035060	Trailer Wiring Harness	1
9			1
10			1

WHEN ORDERING PARTS, BE SURE TO STATE SERIAL NUMBER OF MACHINE

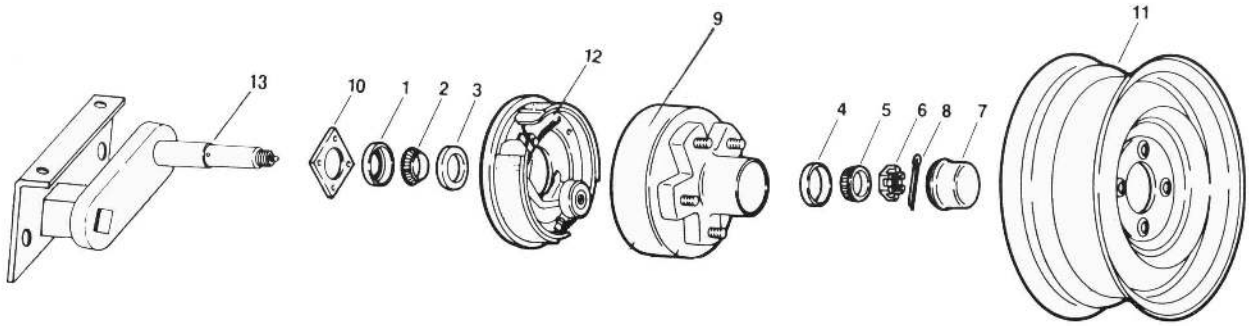

AXLE & HUB ASSEMBLY

Ref. No.	Part No.	Description	No. Req'd
	055503	Axle Assembly	2
1	WL10-9	Grease Seal	1
2	WL31-31-2	Inner Bearing Cone	1
3	WL31-31-1	Inner Bearing Cup	1
4	WL31-31-1	Outer Bearing Cup	1
5	WL31-31-2	Outer Bearing Cone	1
6	WL6-1	Spindle Nut	1
7	WL21-3	Grease Cap	1
8	WL19-2	Cotter Pin	1
9	WL8-257-4	Hub & Drum	1
	WL25-53	½ - 20 Stud	5
10	WL4-54	Brake Flange	1
11	055493	Rim & Tire Assembly	1
	055493-R	Rim	1
	055493-T	Tire	1
12	WL23-47	Left-Hand Brake Assembly	1
	WL23-48	Right-Hand Brake Assembly	1
13		Standard Axle Beam	

WHEN ORDERING PARTS, BE SURE TO STATE SERIAL NUMBER OF MACHINE

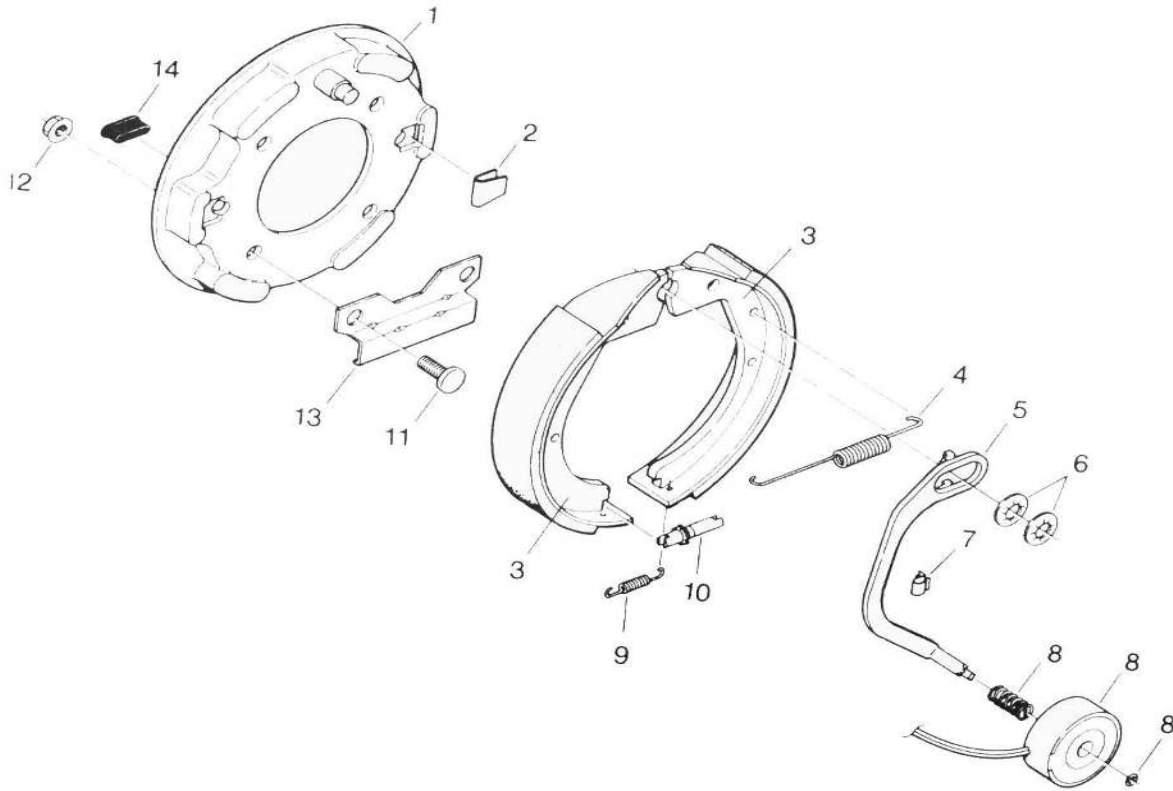

BRAKE ASSEMBLY

Ref. No.	Part No.	Description	No. Req'd
	WL23-47	Left-Hand Brake Assembly	1
	WL23-48	Right-Hand Brake Assembly	1
1	WL36-36-4	Backing Plate Assembly	1
2	WL46-23	Shoe Hold Down Spring	2
3	WL71-45	Shoe & Linkage Kit:	1
	WL40-49	Secondary S & L	1
	WL40-125	Primary S & L	1
4	WL46-24	Retractor Spring	1
5	WL47-29-4	Left-Hand Actuating Lever Arm	1
	WL47-30-4	Right-Hand Actuating Lever Arm	1
6	WL46-30	Anchor Post Clip	2
7	WL27-5	Wire Clip	1
8	WL71-56	Magnet Kit:	1
	WL49-39	Magnet Clip	1
	WL42-114	Magnet	1
	WL46-25	Magnet Spring	1
	WL46-24	Return Spring	1
9	WL46-22	Adjusting Screw Spring	1
10	WL43-21	Adjusting Screw	1
11	WL7-41	Brake Mounting Bolt	4
12	WL6-17	Brake Mounting Nut	4
13	WL64-1	Stabilizer Bracket	1

WHEN ORDERING PARTS, BE SURE TO STATE SERIAL NUMBER OF MACHINE

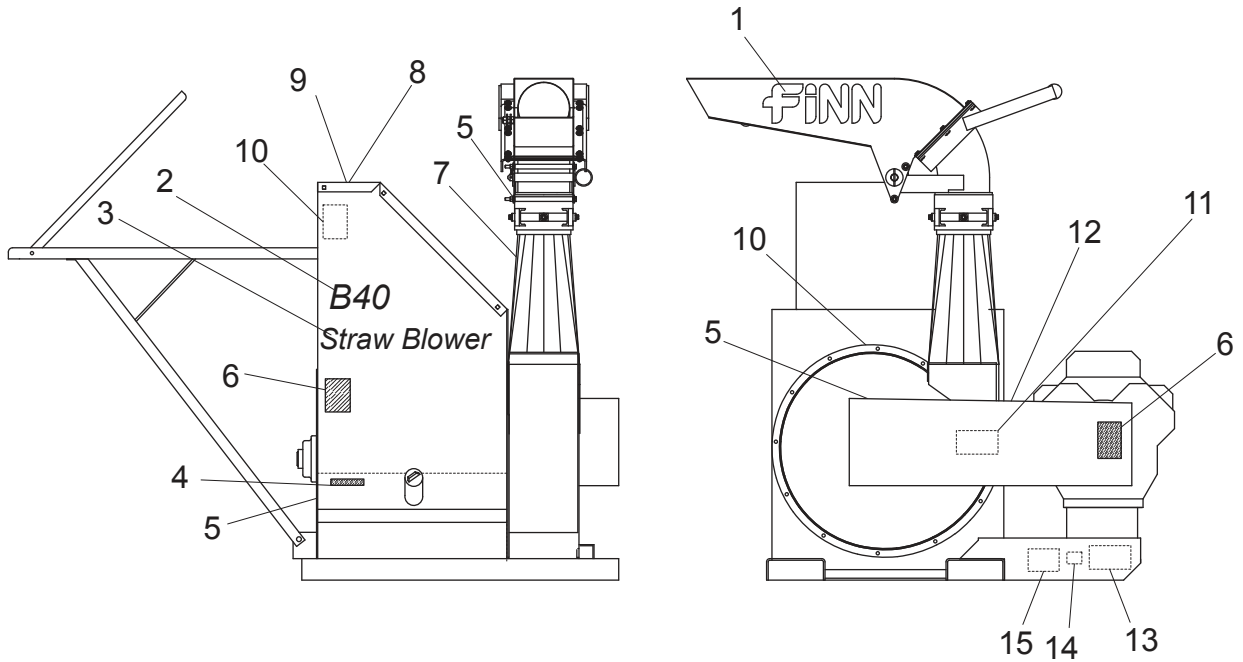

DECALS

Ref. No.	Part No.	Description	No. Req'd
1	031235	Decal "FINN"	2
2	023856-03	Decal "B40"	2
3	023855	Decal "Straw Blower"	2
4	031331	Decal "Gasoline"	1
5	007231	Decal "Service Weekly"	3
6	012179	Decal "Warning Do Not..."	2
7	055280	Decal "Warning Thrown..."	1
8	023519	Decal "Cation Wear Eye..."	1
9	020068	Deacl "Danger Rotating..."	2
10	035106	Decal "Operating instructions..."	1
11	035101	Decal "Caution Area..."	1
12	012278	Decal "Danger Hot Exhaust"	1
13	011690	Finn Name Plate	1
14	020976	Decal "Patent Infringement"	1
15	012260	Mantain Saferly Deacl Plate	1

WHEN ORDERING PARTS, BE SURE TO STATE SERIAL NUMBER OF MACHINE

WARRANTY

Finn warrants to the original Purchaser for use (or rental to others for use) all new construction machinery and attachments therefore manufactured by Finn to be free from defects in material and workmanship for a period of 12 months from date of purchase or 1200 hours of use, whichever comes first. Replacement parts provided under the terms of this warranty are warranted for the remainder of the warranty period applicable to the product in which installed, as if such parts were original components of that product. Finn makes no warranty with respect to (a) allied equipment or trade accessories not manufactured by it (such as, but not limited to tires, ignitions, starters, hose, batteries, magnetos, carburetors, engines or like or unlike equipment or accessories), such being subject to the warranty, if any, provided by their respective manufactures; or (b) secondhand, used, altered, or rebuilt machines. Further, the warranty herein expressed shall be rendered null and void to the extent any defect or failure of the products warranted hereby arises out of or is caused by accessories or component parts not manufactured or supplied by Finn, whether same are supplied by Purchaser, dealers or any other party. THE WARRANTY DESCRIBED IN THIS PARAGRAPH SHALL BE IN LIEU OF ALL OTHER WARRANTIES, EXPRESS OR IMPLIED, INCLUDING, BUT NOT LIMITED TO, ANY IMPLIED WARRANTY OF MERCHANTABILITY OR FITNESS FOR A PARTICULAR PURPOSE.

Upon notification of Finn during the above-stated warranty period of any failure to conform to this warranty, and upon inspection by Finn to verify said nonconformity and verify the continuing existence of the warranty period, Finn will provide a new part or a repaired part, whichever Finn elects, to replace the part found to be defective. Such parts will be provided without charge to the Purchaser during normal working hours at a place of business of a Finn dealer or other establishment authorized by Finn to effect said repairs or replacements, but Purchaser shall bear all costs of transporting the product to and from such place of business or establishment. Correction of nonconformities, in the manner and for the period time provided above, shall constitute fulfillment of all liabilities of Finn under this contract.

THE REMEDIES OF THE USER SET FORTH HEREIN ARE EXCLUSIVE, WITHOUT REGARD TO WHETHER ANY DEFECT WAS DISCOVERABLE OR LATENT AT THE TIME OF DELIVERY OF THE PRODUCT TO THE PURCHASER.

The essential purpose of this exclusive remedy shall be to provide the Purchaser with repair or replacement of parts that prove to be defective within the period and under the conditions previously set forth. This exclusive remedy shall not have failed of its essential purpose (as that term is used in the Uniform Commercial Code) provided Finn remains willing to repair or replace defective parts within a commercially reasonable time after it obtains actual knowledge of the existence of a particular defect.

IN NO EVENT SHALL FINN BE LIABLE FOR ANY SPECIAL, CONSEQUENTIAL, INCIDENTAL OR INDIRECT DAMAGES, INCLUDING LOST PROFITS OR LOST COMMERCIAL OPPORTUNITIES, WITH RESPECT TO THE SALE OF THE ABOVE WARRANTED PRODUCT OR ANYTHING DONE IN CONNECTION THEREWITH, OR FOR PROPERTY DAMAGE SUSTAINED BY A PERSON CLAIMING TO BE A THIRD PARTY BENEFICIARY OF A SURVIVING WARRANTY UNDER THE LAW OF ANY JURISDICTION.

NOTICE

FINN CORPORATION URGES THE USE OF ONLY FINN CORPORATION SUPPLIED PARTS AND ATTACHMENTS TO ASSURE PROPER PERFORMANCE AND SAFE OPERATION OF FINN CORPORATION EQUIPMENT. INSIST ON PARTS AND ATTACHMENTS MANUFACTURED OR SUPPLIED BY FINN CORPORATION WHEN YOU PURCHASE, REPAIR OR REPLACE YOUR FINN EQUIPMENT AND ATTACHMENTS. BECAUSE FINN CORPORATION CANNOT ASSURE THAT PARTS AND ATTACHMENTS NOT MANUFACTURED OR SUPPLIED BY FINN MEET FINN CORPORATION'S QUALITY STANDARDS, SPECIFICATIONS, OR OPERATING REQUIREMENTS, OUR WARRANTY IS NOT EFFECTIVE TO THE EXTENT ANY FAILURE OF OR DEFECT IN A FINN CORPORATION PRODUCT ARISES FROM OR IS CAUSED BY PARTS, ATTACHMENTS OR COMPONENTS NOT ORIGINATING WITH FINN CORPORATION. USE OF FINN CORPORATION EQUIPMENT WITH PARTS AND ATTACHMENTS NOT MANUFACTURED OR SUPPLIED BY FINN COULD RESULT IN PERSONAL INJURY.

Effective December 8, 1995

CALIFORNIA

Proposition 65 Warning

The engine exhaust and some of its constituents are known to the State of California to cause cancer, birth defects, and other reproductive harm.

CALIFORNIA

Proposition 65 Warning

Battery posts, terminals and related accessories contain lead and lead compounds, chemicals known to the State of California to cause cancer and reproductive harm. Wash hands after handling.