

**FINN****HydroSeeder®****Model T120**

T120 HydroSeeder Gooseneck Trailer. (T120GN)

The FINN T120 HydroSeeder is a real workhorse with a 1,000 gallon working tank capacity. FINN developed HydroSeeder technology in 1953. We've been the industry leader in quality and innovation ever since. With the FINN T120, you don't have to settle for less than proven FINN quality to tackle a wide range of highly demanding hydroseeding applications.

### Power To Spare.

The T120 provides muscle with a rugged and dependable 35.1 hp, 3 cylinder water cooled Yanmar diesel engine. Available in skid, gooseneck trailer, or straight pull trailer configurations, the T120 HydroSeeder covers up to 1/3 of an acre with one full tank. Tower discharge distance reaches up to 180 feet for greater slurry application and efficient coverage. In addition, the T120 is equipped with full deck railing and plenty of storage capacity to carry extra materials.

### Positive Control.

The FINN T120 HydroSeeder features a heavy-duty agitator driven by a variable speed, reversible hydraulic motor. The agitator and pump are independently driven, allowing for complete mixing of the slurry without pump operation, and FINN's direct drive clutch and pump assembly are specifically designed to optimize horsepower efficiency and maximize pump performance. Other features include independent rubber torsion suspension

axles that are equipped with electric brakes, including break-away switch; and a direct drive clutch with an adjustable external wear plate.

As the world leader for over 80 years in the design and manufacture of innovative, quality equipment for the green industry, and as the inventor of the HydroSeeder, FINN Corporation is committed to your complete satisfaction.



T120 HydroSeeder Straight Pull Trailer. (T120T)



T120 HydroSeeder Skid Mounted. (T120S)

*Models shown include optional equipment.*

[FINNcorp.com](http://FINNcorp.com)

**FINN**  
SMARTER WAYS TO WORK™

# FINN HydroSeeder®

## Model T120 with Tier 4F Engine

### T120GN GOOSENECK TRAILER

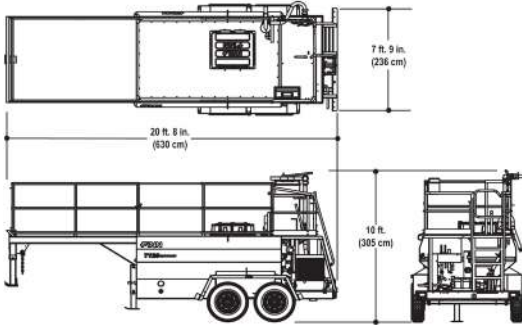

### T120T STRAIGHT PULL TRAILER

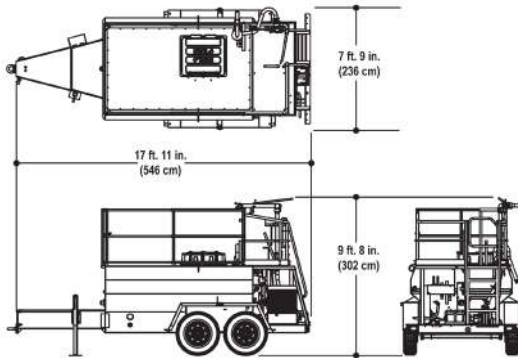

### T120S SKID MOUNT

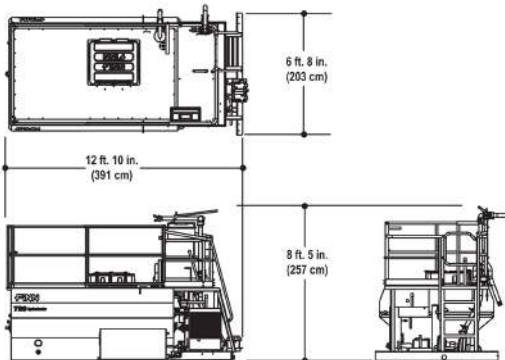

### FINN MODEL T120 TECHNICAL SPECIFICATIONS

POWER .....	Yanmar 3TNV88C-DYEM, 35.1hp (26.2kw), 3 cylinder water cooled diesel engine. Tier 4Final. 1.642L
ENGINE SAFETY SYSTEM .....	Low oil pressure, electronic engine control and monitoring
TANK SIZE .....	1,180 gallon (4,468 liter) liquid capacity, 1,000 gallon (3,785 liter) working capacity
LOADS PER ACRE <sup>1</sup> .....	3
FUEL TANK CAPACITY .....	13.5 gallon (51.1 liter)
PUMP .....	Centrifugal 4" x 2" (10 cm x 5 cm) 170 gpm @ 100 psi (646 lpm @ 7 kg/cm <sup>2</sup> ), 3/4" (1.9 cm) solid clearance, external adjustment
PUMP DRIVE .....	Direct drive with over center clutch, pump drive is independent of agitator operation
AGITATION .....	Mechanical paddle agitation and liquid recirculation
AGITATOR DRIVE .....	Reversible, variable speed hydraulic motor drive (0-100 rpm)
DISCHARGE DISTANCE .....	Up to 180 feet (55 m) from end of discharge tower
MAX. MATERIAL CAPACITY .....	3,200 lbs. (1,450 kg) granular solids 500 lbs. (225 kg) fiber mulch
NOZZLES .....	(1) narrow fan, (1) wide fan, (2) long distance
EMPTY WEIGHT <sup>2</sup> .....	T120GN 7,010 lbs. (3,180 kg) T120T 6,170 lbs. (2,799 kg) T120S 4,580 lbs. (2,077 kg)
WORKING WEIGHT <sup>2</sup> .....	T120GN 18,730 lbs. (8,496 kg) T120T 17,900 lbs. (8,119 kg) T120S 16,300 lbs. (7,394 kg)
BRAKES .....	Electric on both axles with break-away switch
LIGHTS .....	D.O.T. including marker, identification lights and license plate bracket
TIRES .....	ST235/85R16 radial, load range E
TRAILER AXLES .....	Tandem 7,200 lbs. (3,266 kg) rubber torsion with fenders
GVWR .....	T120GN 17,900 lbs. (8,119 kg) T120T 17,200 lbs. (7,802 kg)
HITCH WEIGHT .....	T120GN Approx. 3,500 lbs. (1,588 kg) T120T Approx. 2,800 lbs. (1,270 kg)

<sup>1</sup>Loads per acre based on an application rate of 1500 lbs. mulch/acre.

<sup>2</sup>Working weights are approximate and do not include options or stored materials. Working weights assume maximum tank liquid capacity and maximum granular solids material capacity.

FINN Corporation has a policy of continuous product improvement, and reserves the right to change design and specifications without notice.

HydroSeeder® and the FINN Design® Logo are registered trademarks of FINN Corporation.



9281 LeSaint Drive • Fairfield, OH 45014-5457  
Toll Free 800.543.7166 / 513.874.2818  
FINNcorp.com