

T75T HYDROSEEDER®
TRAILER

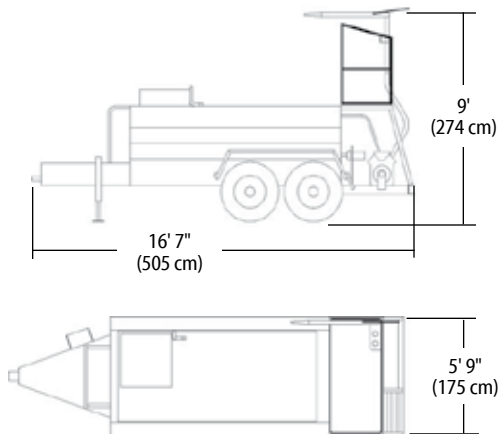

T75S HYDROSEEDER®
SKID MOUNT

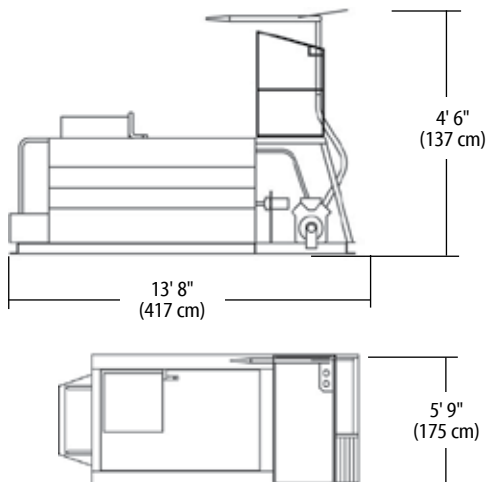

FINN MODEL T75 TECHNICAL SPECIFICATIONS

POWER	Kohler Ch25, 25 hp (18.7 kw), 2 cylinder, OHV, air cooled, gas	
ENGINE SAFETY SYSTEM	Low oil pressure, high water temperature shutoff	
TANK SIZE	820 gallon (3,100 liter) liquid capacity, 700 gallon (2,650 liter) working capacity	
FUEL TANK CAPACITY	10 gallon (38 liter)	
PUMP	Centrifugal 3" x 1-1/2" (7.5 cm x 3.75 cm), 135 gpm @ 65 psi (511 liter pm @ 448 kPa) with 3/4" (1.9 cm) solid clearance, adjustable	
PUMP DRIVE	Direct drive through electric clutch, Pump drive is independent of agitator operation	
AGITATION	Mechanical paddle agitation and liquid recirculation	
AGITATOR DRIVE	Reversible, variable speed hydraulic motor drive (0-110 rpm), with control lever at front and rear of unit	
DISCHARGE DISTANCE	Up to 150 feet (45 m) from end of discharge tower	
MATERIAL CAPACITY	2,333 lbs. (1,058 kg) granular solids, 350 lbs. (159 kg) fiber mulch	
NOZZLES	(1) narrow fan, (1) wide fan, (2) long distance	
BRAKES	Electric with break-away switch	
LIGHTS	D.O.T., including identification lights and license plate bracket	
TIRES	ST225/75R15 load range D highway tread	
TRAILER AXLES	Tandem 5,000 lbs. (2,273 kg) rubber torsion with fenders	
HITCH	2 5/16" (5.87 cm) ball or heavy-duty lunette eye Includes large storage area in tongue	
HITCH WEIGHT	Approx. 1,400 lbs. (636 kg) maximum loaded	
EMPTY WEIGHT	T75T	3,250 lbs. (1,477 kg)
	T75S	2,450 lbs. (1,114 kg)
WORKING WEIGHT*	T75T	9,990 lbs. (4,541 kg)
	T75S	9,190 lbs. (4,177 kg)