

T400 HYDROSEEDER[®]

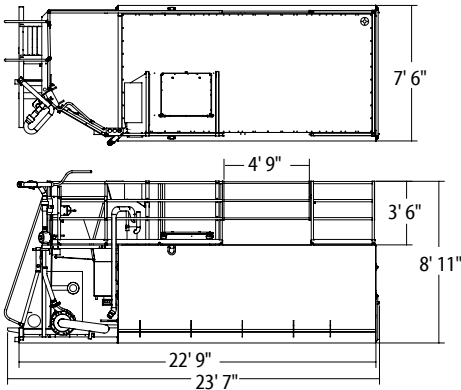

T330 HYDROSEEDER[®]

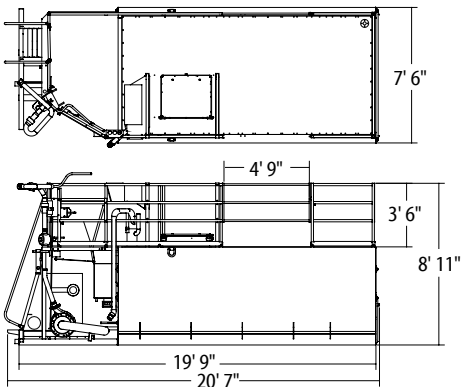

T280 HYDROSEEDER[®]

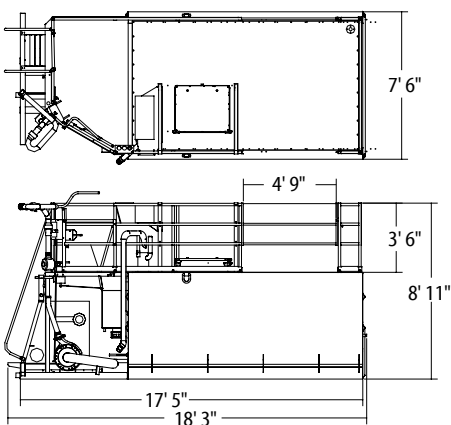

FINN MODEL T280/T330/T400 TECHNICAL SPECIFICATIONS

POWER	John Deere 4045T (4.5 L) Tier II compliant industrial water-cooled ,115 hp Turbo Diesel, with over-center clutch. Vibration isolated. Control panel with digital engine information display, throttle, pump on/off, horn
ENGINE SAFETY SYSTEM	Engine ECU with self-diagnostics including low oil pressure, high temperature shutoff
TANK SIZE	T400 3,975 gallon (15,047 liter) liquid capacity, 3,600 gallon (13,627 liter) working capacity T330 3,350 gallon (12,681 liter) liquid capacity, 3,000 gallon (11,356 liter) working capacity T280 2,750 gallon (10,410 liter) liquid capacity, 2,500 gallon (9,464 liter) working capacity
FUEL TANK CAPACITY	38 gallon (144 liter)
PUMP	Centrifugal 5" x 2-1/2" (12.7 cm x 6.4 cm) 400 gpm @ 130 psi, 1" (2.5 cm) solid clearance
PUMP DRIVE	In-line coupled to air-controlled over-center clutch, pump drive is independent of agitator operation
AGITATION	Twin mechanical paddle agitators and liquid recirculation
AGITATOR DRIVE	Reversible, variable speed hydraulic motor drive (0-130 rpm)
DISCHARGE DISTANCE	Up to 230 ft. (70 m) from discharge tower
MATERIAL CAPACITY	T400 12,400 lbs. (5,625 kg) granular solids, 1,800 lbs. (816 kg) fiber mulch T330 10,000 lbs. (4,536 kg) granular solids, 1,500 lbs. (680 kg) fiber mulch T280 8,000 lbs. (3,630 kg) granular solids, 1,250 lbs. (570 kg) fiber mulch
NOZZLES	(2) narrow fan, (2) wide fan, (2) long distance
EMPTY WEIGHT	T400 10,436 lbs. (4,734 kg) T330 9,600 lbs. (4,354 kg) T280 8,950 lbs. (4,060 kg)
WORKING WEIGHT*	T400 44,000 lbs. (19,958 kg) T330 42,000 lbs. (19,051 kg) T280 35,600 lbs. (16,148 kg)
LOADING HATCH	Large sealed hatch with 24-1/2" x 29-1/2" opening and a pivoting stainless steel bag cutter and safety grate