



LF120 Landfill Machine Straight Pull Trailer.

The FINN LF120 Landfill Machine is a real workhorse with a 1,000 gallon working tank capacity. FINN developed HydroSeeder technology in 1953. We've been the industry leader in quality and innovation ever since. With the FINN LF120, you don't have to settle for less than proven FINN quality to tackle a wide range of highly demanding hydroseeding applications.

**Power To Spare.** The LF120 provides muscle with a rugged and dependable 33.5 hp, 4 cylinder water cooled Kubota diesel engine. The LF120 Landfill Machine covers up to 1/5 of an acre with one full tank. Tower discharge distance reaches up to 180 feet for greater slurry application and efficient coverage. In addition, the LF120 is equipped with full deck railing and plenty of storage capacity to carry extra materials.

**Positive Control.** The FINN LF120 Landfill Machine features a heavy-duty agitator driven by a variable speed, reversible hydraulic motor. The agitator and pump are independently driven, allowing for complete mixing of the slurry without pump operation, and FINN's direct drive clutch and pump assembly are specifically designed to optimize horsepower efficiency and maximize pump performance.

Other features include independent rubber torsion suspension axles and a direct drive clutch with an adjustable external wear plate.

As the world leader for over 70 years in the design and manufacture of innovative, quality equipment, FINN Corporation is committed to your complete satisfaction.

### SMARTER WAYS TO WORK

9281 LeSaint Drive Fairfield, OH 45014-5457 Phone (513) 874-2818 Fax (513) 874-2914  
Toll Free (800) 543-7166 Parts (800) 229-8707 E-mail: sales@finncorp.com  
Customer Service/Warranty (888) 382-1966

[www.finncorp.com](http://www.finncorp.com)

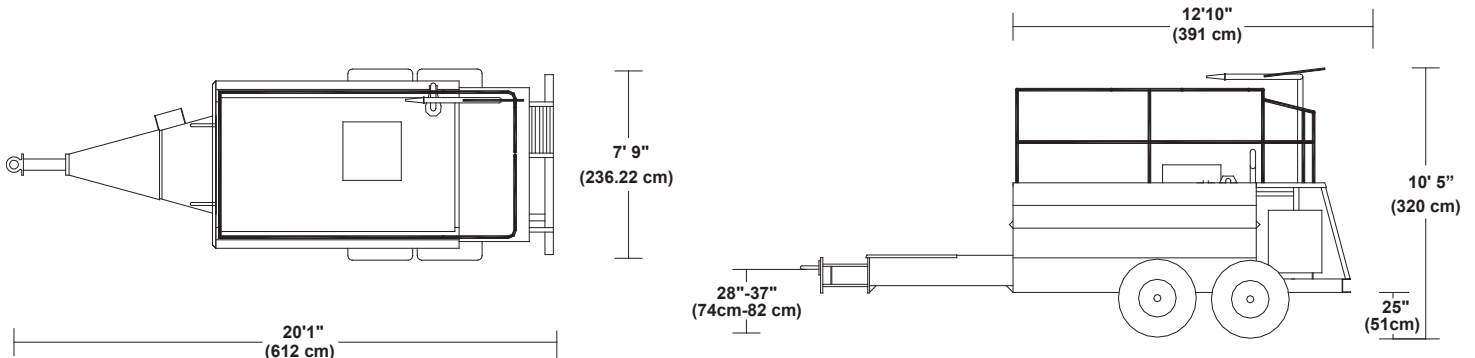

LF120 STRAIGHT PULL TRAILER

## FINN MODEL LF120 TECHNICAL SPECIFICATIONS

|                              |   |
|------------------------------|---|
| POWER.....                   | Diesel Kubota V1505, 33.5 hp (25 kw),<br>4 cylinder water cooled  |
| ENGINE SAFETY SYSTEM .....   | Low oil pressure, high water temperature shutoff  |
| TANK SIZE.....               | 1,180 gallon (4,468 liter) liquid capacity,<br>1,000 gallon (3,785 liter) working capacity  |
| FUEL TANK CAPACITY .....     | 15 gallon (57 liter)  |
| PUMP .....                   | Centrifugal 4" x 2" (10 cm x 5 cm) 170 gpm<br>@ 100 psi, (646 lpm @ 7 kg/cm <sup>2</sup> ), 3/4" (1.9 cm)<br>solid clearance, external adjustment |
| PUMP DRIVE .....             | Direct drive with over center clutch,<br>pump drive is independent of agitator operation  |
| AGITATION .....              | Mechanical paddle agitation and liquid recirculation  |
| AGITATOR DRIVE.....          | Reversible, variable speed hydraulic motor drive<br>(0-110 rpm)   |
| DISCHARGE DISTANCE.....      | Up to 180 feet (55 m) from end of discharge tower   |
| MAX. MATERIAL CAPACITY ..... | 3,200 lbs. (1,450 kg) granular solids,<br>500 lbs. (225 kg) fiber mulch   |
| NOZZLES.....                 | (1) narrow fan, (1) wide fan, (2) long distance   |
| EMPTY WEIGHT.....            | 5,800 lbs. (2,636 kg)   |
| WORKING WEIGHT*.....         | 17,500 lbs. (7,954 kg)  |
| TIRES .....                  | Hi flotation agricultural 16.5L -16.1 SL tubeless with<br>wide tread design and large footprint   |
| TRAILER AXLES.....           | High clearance heavy duty tandem<br>10,000 lbs. (4,545 kg) rubber torsion   |

\*Working weights are approximate and do not include options or stored materials.

FINN Corporation has a policy of continuous product improvement, and reserves the right to change design and specifications without notice.

HydroSeeder® is a registered trademark of the FINN Corporation.