

B70T TRAILER

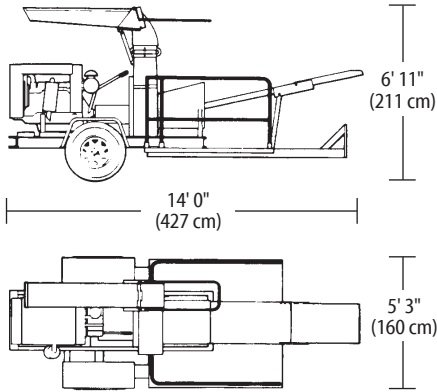

B70S SKID MOUNT

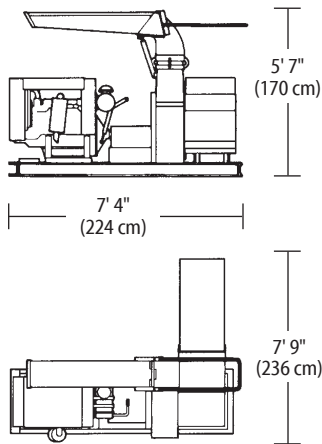

FINN MODEL B70 TECHNICAL SPECIFICATIONS

POWER	Diesel Kubota V1505, 33.5 hp (25 kw), 4 cylinder water cooled diesel engine with over-center clutch
ENGINE SAFETY SYSTEM	Low oil pressure, high water temperature shutoff
CAPACITY	Up to 7 tons of hay or straw per hour
FUEL TANK CAPACITY	13.5 gallon (51 liter)
BLOWER.....	Dynamically balanced, 21" (53 cm) diameter fan with 6 blades developing a discharge velocity greater than 150 mph (240 km/h)
RANGE	60 ft. (18 m) in still air
FEED	Manual
BEATER CHAMBER.....	3.5 cu. ft. (99 liter) with removable beater chains
DISCHARGE SPOUT	Block bearing mounted. 360 degrees horizontal rotation and 70 degrees vertical travel
TRAILER OPTION	Independent suspension rubber torsion axle, 75 R/15 load range B, highway tread radial tires, fenders, D.O.T highway lights, dual skid proof operator platforms, parking jack, 2" (5 cm) ball or heavy duty eye hitch
FEED TRAY	Folding tray, adjustable height to meet bed of supply vehicle
DRIVE.....	Blower fan in-line coupled to over-center clutch with flexible coupling and two pillow block bearings
WEIGHT	B70S 1,590 lbs. (721 kg) B70T 2,250 lbs. (1020 kg)

FINN Corporation has a policy of continuous product improvement, and reserves the right to change design and specifications without notice.