

### B260T TRAILER

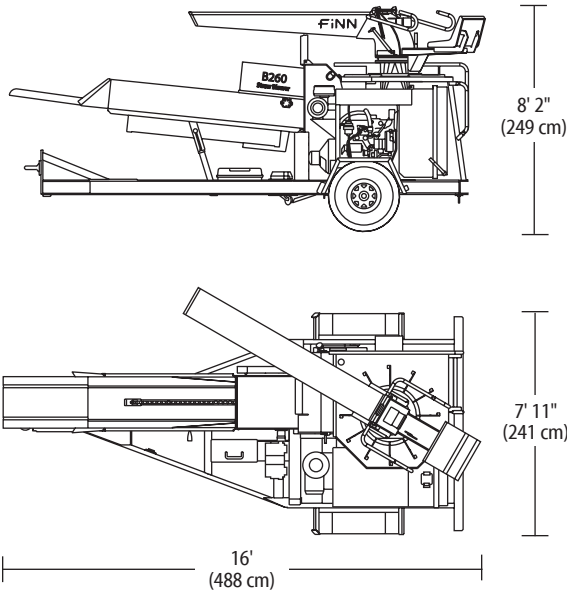

### B260S SKID MOUNT

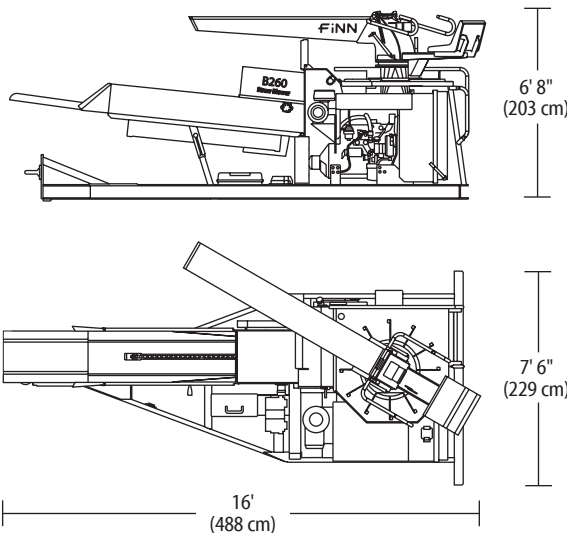

### FINN MODEL B260 TECHNICAL SPECIFICATIONS

POWER .....	John Deere Tier II Diesel 4045T (4.5 liter), 115 hp Turbo with over-center clutch
ENGINE SAFETY SYSTEM .....	Engine ECU control with self diagnostics. Includes low oil pressure and high water temperature, automatic derate, and shut-off.
CAPACITY .....	Up to 20 tons of straw per hour
FUEL TANK CAPACITY .....	28 gallon (106 liter)
BLOWER.....	Dynamically balanced, 30" (76 cm) diameter fan with 6 blades developing a velocity greater than 185 mph (298 kph)
RANGE.....	Up to 100 ft. (30 m) in still air
FEED TRAY .....	Hydraulic powered conveyor chain with variable speed control. Tray includes an adjustable elevation and length to meet the bed of supply vehicle
BEATER CHAMBER.....	15 cu. ft. (425 liter) with 8 removable beater fingers for separating straw. Accepts both 2-string and 3-string rectangular bales
DISCHARGE TUBE .....	Ball bearing mounted. 355 degree horizontal rotation, 60 degree vertical travel with gas spring counter balance
FRAME & TRAILER .....	Heavy-duty 6" (15.2 cm) channel with a 6,000 lb. (2,730 kg) rubber torsion axle, 750 x 16 F rated highway tread, swing away parking jack, heavy-duty tow eye, fenders, flashing warning light, and DOT highway lights
OPERATOR STATION .....	Adjustable padded seat with fold-up arm rests mounted on the discharge head. Control panel includes digital engine information display, throttle, engine start/stop, horn and full discharge tube control. Centrally located power feed control and clutch lever within arms reach of operators station
DRIVES.....	Blower fan driven by power band belt. Feed chute roll and chain hydraulically driven with variable speed control
WEIGHT .....	B260T 4,800 lbs. (2,177 kg) B260S 4,400 lbs. (1,996 kg)
BRAKES.....	Electric with breakaway switch
OPERATOR SAFETY.....	Emergency shutdown buttons on feed tray and interlock switches on all access doors

FINN Corporation has a policy of continuous product improvement, and reserves the right to change design and specifications without notice.