



TITAN 280/330/400 HYDROSEEDER®

TITAN

MORE HORSEPOWER WITH HIGH EFFICIENCY HYDRAULIC SYSTEM

- 170HP Tier III Cummins water cooled, turbo-diesel engine
- Self-diagnosing engine including low oil pressure and high temperature shut-off system
- Electronically controlled hydraulics to enable maximum torque and speed control
- 6 x 3 inch, in-line 500gpm centrifugal pump
- Two (2) heavy duty, reversible and variable speed mechanical agitators with liquid recirculation
- Independent agitator control for more efficient loading

MORE FLEXIBILITY

- Single boom, dual boom or hose application
- Mix and spray any material from the heaviest slurry BFM's, FGM's, plaster-based additives, lime, sprigs and stolons
- Variable speed agitators independent from pump
- Air-flush system available
- Air-activated clutch
- 4000, 3000 or 2800 gallon tank capacity

MORE VERSATILITY AND SPEED

- High power agitators for tough/heavy slurries
- 6 inch suction hose for faster unloading – unit will unload in 6-8 minutes, ideal for re-vegetation using aircraft or large area coverage

MORE FEATURES AND BENEFITS

- Spraying distances of over 320 feet from boom
- Dual boom as an option for spraying on both sides of the unit for hard-to reach areas
- Hydraulic hose reel for ease of use
- Larger hatch design & bigger fill-port for quicker, more efficient loading
- Can accommodate 2-man loading at the same time.
- Larger slide-gate and open-space design dramatically increases the amount of usable storage space on top of the tank
- Full operation remote control of agitator speed and mixing direction, pump, throttle and hose rewind

MORE DURABLE AND RELIABLE

Exactly what you would expect from a **FINN**

Note: Some features listed are options at an extra cost. See a sales representative or dealer for further details



9281 LeSaint Drive
Fairfield, OH 45014

(800) 543-7166
sales@finncorp.com
www.finncorp.com



TITAN 280/330/400 HYDROSEEDER®

TITAN 400 HYDROSEEDER®

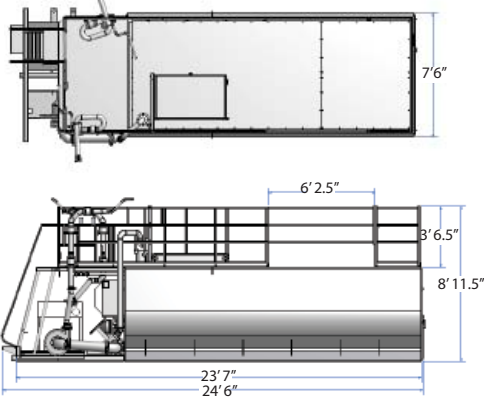

TITAN 330 HYDROSEEDER®

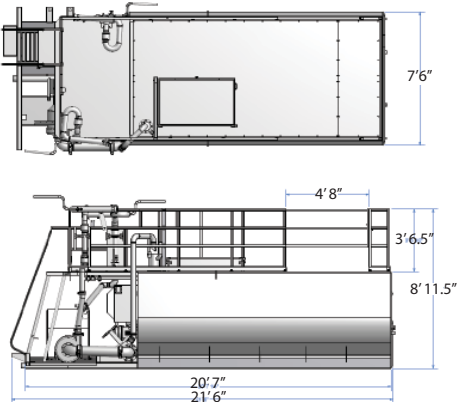

TITAN 280 HYDROSEEDER®

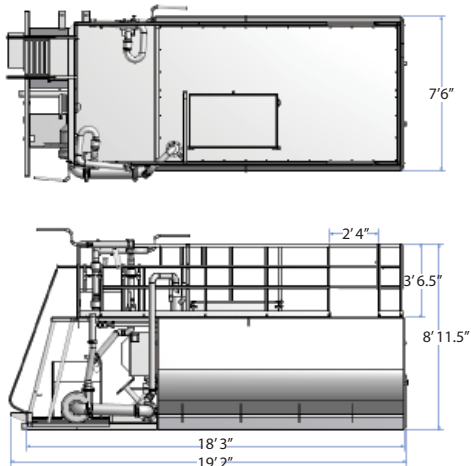

TECHNICAL SPECIFICATIONS

POWER Cummins QSB (4.5 L) Tier III compliant industrial water-cooled, 170 hp Turbo Diesel, with over-center clutch. Vibration isolated. Control panel with digital engine information display, throttle, pump on/off, horn, agitator direction and speed controls, e-stop

ENGINE SAFETY SYSTEM Engine ECU with self-diagnostics including low oil pressure and high temperature shutoff

TANK SIZE..... Titan 400 3,975 gallon (15,047 liter) liquid capacity, 3,600 gallon (13,627 liter) working capacity
Titan 330 3,350 gallon (12,681 liter) liquid capacity, 3,000 gallon (11,356 liter) working capacity
Titan 280 2,750 gallon (10,410 liter) liquid capacity, 2,500 gallon (9,464 liter) working capacity

FUEL TANK CAPACITY 38 gallon (144 liter)

PUMP Centrifugal 6" x 3" (15.2 cm x 7.6 cm) 500 gpm @ 175 psi, 3/4" solid clearance

PUMP DRIVE In-line coupled to air-controlled clutch, pump drive is independent of agitator operation

AGITATION..... Two (2) mechanical paddle agitators and liquid recirculation

AGITATOR DRIVE..... Reversible, variable speed hydraulic motor/gearbox drive (0-135 rpm) on agitators

DISCHARGE DISTANCE Up to 320 ft. (97.5 m) from discharge tower

MATERIAL CAPACITY Titan 400 12,400 lbs. (5,625 kg) granular solids, 1,800 lbs. (816 kg) fiber mulch
Titan 330 10,000 lbs. (4,536 kg) granular solids, 1,500 lbs. (680 kg) fiber mulch
Titan 280 8,000 lbs. (3,630 kg) granular solids, 1,250 lbs. (570 kg) fiber mulch

MATERIAL CARRYING CAPACITY Titan 400 12,000 lbs. (5,443 kg) material
Titan 330 12,000 lbs. (5,443 kg) material
Titan 280 10,000 lbs. (4,536 kg) material

NOZZLES (2) narrow fan, (2) wide fan, (2) long distance for boom

EMPTY WEIGHT..... Titan 400 13,180 lbs. (5,978 kg)
Titan 330 12,340 lbs. (5,600 kg)
Titan 280 11,690 lbs. (5,300 kg)

WORKING WEIGHT..... Titan 400 46,750 lbs. (21,200 kg)
Titan 330 44,750 lbs. (20,300 kg)
Titan 280 38,350 lbs. (17,390 kg)

LOADING HATCH..... Large steel hatch with 28½" x 48" opening and dual pivoting stainless steel bag cutter and safety bar

OPTIONAL EQUIPMENT..... Second discharge boom, Hose reel package, Remote control, Air flush, Third (3rd) Agitator